

## Document Control

Issue Date	Comments	Revisions	Revision #
3/5/99	Draft		
7/23/99	Draft 2		
12/30/99	Incorporate Bayne Smith's comments Revise external transceivers to specifically prohibit internal card type and to reword compliance with NEMA environmental rqmts to match video transceiver wording. Add test requirements for ATM switch and RS232 terminal server Revise specifications for video monitor Revise reference to existing video multiplexer protocol from VisiMux 8000 to VisiMux 2000. Revise ATM/Ethernet Switch requirements to match recent changes in 935Base.doc.	939.2B1  935.3.06A4 and A5  939.2A6 939.3.05A9  935.2A10	1
1/12/00	Delete Uninterruptable Power Supply	939.2.A.7	2
1/12/00	Project: CM-00TS(10) Ct. 1 Fulton County P.I. No. 713155 Project: CM-00TS(10) Ct. 2 DeKalb And Fulton County P.I. No. 713157		
2/3/00	Project: CM-056-1(57) Fulton County P.I. No. 721950		
3/8/00	Revise Cabinet types from 1,2,3 to A,B,C		3
3/17/00	Add Measurement section for power service assembly and include timber pole	939.4.05.C.5.c	4
3/24/00	Revise submittal requirements Revise video transport system	939.1.03 939.2.A.2.a; 939.3.05.A.2	5
3/29/00	Revise equipment "rack" to "hub" equipment "cabinet"; add new equipment rack spec; revise submittal chart. Correct reference to Detail Dwg. 939.7	939.2.A.1; 939.2.A.17; 939.1.03  939.2.C.2.d	6
4/3/00	Project: CM-285-1(360) DEKALB COUNTY P.I. NO. 713410		
5/31/00	Project: STP-7713(650) Fulton County P.I. No. 771365		
6/13/00	Delete test lab requirements for serial data terminal serve; add test lab reports for transmitter/rcvr/modem	939.1.03	7
11/13/00	Delete Video/Data Transceiver-Telephone (Type C). Separate slow scan transceiver into	939.2.B.5  939.2.B.6, 939.2.B.7	8

## Document Control

Issue Date	Comments	Revisions	Revision #
	transmitter and receiver; standardize naming to match payitem descriptions. Allow transmitter to be rack or wall mount. Delete comm protocol rqmts duplicated in 939.3.05.B.2.c.; separate sections for transmitter and receiver Add section for public network slow scan video receiver; renumber the sections following. Add "Public Network" to description of slow-scan video transmitter and receiver items.	939.2.B.6 939.3.05.B.4  939.3.05.B.5, 939.3.05.B.6, 939.3.05.B.7, 939.3.05.B.8  939.5	
12/6/00	Delete metric equivalents	Various locations	9
2/9/01	Change transceivers to separate transmitters and receivers	939.2.B.4	10
2/9/01	Document Control No. NAV01-053		1.0
2/14/01	Entered into CM Document Control		1.0
3/9/01	SCR # 45 Revise transceiver power budgets	Section 939.2.B.1 Section 939.2.B.3 Section 939.2.B.4 Section 939.2.B.5	1.1
4/4/01	Updated QAed. New release of document		2.0
7/6/01	Updated as per SCR # 232.	Section 939.2.B.14 Section 939.3.05.B.9 Section 939.5	2.1
7/6/01	New revision published to server		3.0
9/25/01	Updated as per SCR # 191	Section 939.2.B.3	3.1
9/26/01	New revision published to server		4.0
10/26/01	Updated as per SCR #291	939.1.03; 939.2.A.9; 939.3.5.A.8; 939.4.A.10; 939.5	4.1
2/12/02	Updated as per SCR # 280	Section 939.3.07	4.2
2/12/02	New revision published to server		5.0
3/29/02	Revised external modem rqmts to ensure rack-mounted in TCCs and hubs	939.2.b.1	5.1
4/11/02	Published to server		6.0
5/21/02	Updated as per SCR # 326	939.2.A.3 939.3.05.A.3	6.1
5/22/02	Published to server		7.0
8/15/02	Inclusion of Metric Equivalent Units (SCR #330) and updated as per SCR #343	939.1.01; 939.2.A.1; 939.2.A.2b; 939.2.A.3; 939.2.A.5; 939.2.A.6;	7.1

## Document Control

Issue Date	Comments	Revisions	Revision #
		939.2.A.7; 939.2.A.8; 939.2.A.9; 939.2.A.11; 939.2.A.13; 939.2.A.15; 939.2.A.17; 939.2.A.18; 939.2.B.1; 939.2.B.3; 939.2.B.4; 939.2.B.5; 939.2.B.10; 939.2.B.11; 939.2.B.12; 939.2.B.13; 939.2.B.14c; 939.2.B.14d; 939.2.C.1; 939.2.C.2b; 939.2.C.2c; 939.2.C.2d; 939.2.C.4; 939.2.C.5; 939.3.04.A; 939.3.05.A.1; 939.3.05.A.4; 939.3.05.A.6; 939.3.05.C.4a; 939.3.05.C.5a; 939.3.05.C.5b; 939.3.05.C.5c	
9/24/02	Published to server.		8.0
11/12/02	Revised per SCR 318 for microwave radar detection	939.3.05.B.1; Details 939.4 & 939.5	8.1
11/13/02	Published to Server		9.0
11/19/02	Modified to meet Office of Contract Administration requirements for format per TOPPS document 2445-1.		9.1
12/19/02	Published to server		10.0
1/16/03	Revised per SCR 244 to add Video Transport System, Type B	939.2.A.2; 939.2.A.2.a; 939.2.A.2.b; 939.2.A.3; 939.3.05.A.2; 939.3.06.A.6; 939.4.A.1; 939.5	10.1
1/21/03	Published to server		11.0
6/18/03	Revised per SCR 407 by Craig Ramsey	939.2.B.1	11.1
6/20/03	Published to server		12.0
8/13/03	Revised as per SCR # 190	939.2.B.3	12.1
8/13/03	Published to server		13.0
10/7/03	Revised as per SCR # 416	939.2.A.10	13.1
10/7/03	Published to server		14.0
9/3/04	Issued to URS (John Portwood) as per SCR # 476		14.1
1/24/05	Revised as per SCR # 476	939.1.01; 939.1.02.B; 939.1.03; 939.1.03.A; 939.2	14.2-4

## Document Control

Issue Date	Comments	Revisions	Revision #
		(multiple subsections); 939.3.04; 939.3.05; 939.3.06; 939.3.08; 939.4; 939.5	
1/26/05	Published to server		15.0

**DEPARTMENT OF TRANSPORTATION  
STATE OF GEORGIA**

**SPECIAL PROVISION**

**PROJECT: [INSERT PROJECT NUMBER(S)]  
[INSERT COUNTY NAME(S)] COUNTIES  
P.I. NO. [INSERT P.I. NUMBER(S)]**

**SECTION 939 – COMMUNICATION AND ELECTRONIC EQUIPMENT**

**Section 939 - Communication and Electronic Equipment**

---

The text included herein is written in the imperative mood (sentences often begin with commands). All commands and references in, or in connection with, the text in this document are written to imply **Contractor responsibility for action** unless otherwise specified.

**939.1 General Description**

This work includes installation, acceptance testing, warranty, and guaranty of items that are either components of several NaviGator subsystems or elements of the communication network.

**939.1.01 Definitions**

Caltrans TEES – Caltrans Transportation Electrical Equipment Specifications, as published by the State of California Business, Transportation & Housing Agency; Department of Transportation, Current Edition, and all current addenda.

Type A Cabinet – The Type A cabinet housing is a standard Model 336 stretch (336S) housing with approximate exterior dimensions of 46 in. (1.2 m) (H) x 24 in. (0.61 m) (W) x 23 in. (0.58 m) (D).

Type B Cabinet - The Type B cabinet housing is a standard Model 337 housing with approximate exterior dimensions of 35 in. (0.89 m) (H) x 20 in. (0.5 m) (W) x 17 in. (0.43 m) (D).

Type C Cabinet - The Type C cabinet housing is a standard Model 332 housing with approximate exterior dimensions of 64 in. (1.6 m) (H) x 24 in. (0.61 m) (W) x 30 in. (0.76 m) (D).

Type D Cabinet – The Type D cabinet housing is a standard Model 336 stretch (336S) housing with approximate exterior dimensions of 46 in. (1.2 m) (H) x 24 in. (0.61 m) (W) x 23 in. (0.58 m) (D). The difference between a Type D and Type A cabinet is the difference in interior cabinet configuration as shown in the Detail Drawings in this section.

**939.1.02 Related References**

**A. Georgia Specifications**

Section 631 – Changeable Message Sign

Section 682 – Electrical Wire, Cable and Conduit

Section 797 – Fiber Optic Building

Section 922 – Electrical Wire and Cable

Section 923 – Electrical Conduit

Section 925 – Traffic Signal Equipment

Section 935 – Fiber Optic Cable

Section 936 – Closed Circuit Television System

Section 937 – Video Detection System

Section 938 – Detection

Section 940 – NaviGAator Advanced Transportation Management System Integration

**B. Referenced Documents**

American Society of Testing and Materials (ASTM)

Caltrans TEES

Electronics Industry Association (EIA)

ICEA Table K.2/Method 1

Institute of Electrical and Electronics Engineers (IEEE)

International Standards Organization (ISO)

International Electrotechnical Commission (IEC)

Motion Pictures Expert Group (MPEG)

National Electric Code (NEC)

National Electrical Manufacturers Association (NEMA)

National Transportation Communications for ITS Protocol (NTCIP)

Underwriter’s Laboratory Incorporated (UL)

**939.1.03 Submittals**

The following chart provides the Contractor with an outline of the submittal requirements for the equipment and components for this pay item. This chart is to be used as a guide and does not relieve the Contractor from submitting additional information to form a complete submittal package.

Item	Specification Subsection	Catalog Cuts	Factory Specifications	Independent Test Lab Certification	Installation Procedure	Maintenance Procedures
Terminal Server	939.2.A.2	X	X		X	X
Video Monitor	939.2.A.4	X	X		X	X
Hub UPS	939.2.A.5	X	X		X	X
Network Switch, Layer 3 Gig-E (All Types)	939.2.A.6	X	X		X	X
GBIC Enterprise Module	939.2.A.7	X	X		X	X
GBICs (All Types)	939.2.A.8	X	X		X	X
Field Switch (All Types)	939.2.A.9	X	X		X	X
Video Encoder & Decoder	939.2.A.10	X	X		X	X
Ethernet Hub	939.2.A.11	X	X		X	X
Navigator Workstation	939.2.A.12	X	X		X	X
Video Recorder	939.2.A.13	X	X		X	X
Equipment Rack	939.2.A.14	X	X		X	
Equipment Frame	939.2.A.15	X	X		X	
Dial-up Modem	939.2.A.16	X	X		X	X
Media Converter	939.2.A.17	X	X		X	X
Equipment Cabinet Assembly	939.2.B	X	X		X	X

Submit submittal data for all equipment, materials, test procedures, and routine maintenance procedures required for these items within 60 calendar days after the Notice To Proceed and prior to any installation, unless noted otherwise in the Contract Documents.

Submit to the Engineer for approval, six (6) copies of the manufacturer's descriptive literature (catalog cuts), technical data, operational documentation, service and maintenance documentation and all other materials required within these specifications.

Provide submittal data that is neat, legible, and orderly. Neatly organize each package of submittal data and separate by hardware item. Use the "Materials Certification Package Index and Transmittal Form", contained in Section 105.02 of the Special Provisions, for each pay item to document and list all material and components that are included in the submittal package. Any submittal data submitted without the Index/Transmittal form or that is incomplete will be rejected.

## A. Equipment

### 1. Equipment

Materials submittal data for items specified herein shall include, but not be limited, equipment performance and technical specifications, electrical/power specifications, size/weight/mounting configuration requirements, and environmental operating conditions.

Provide a diagram showing the location of all equipment within the TCC, Hub and/or Equipment Cabinet, 30 days prior to any installation activities at the site. Include in this diagram the dimensions, power requirements, and heat dissipation specifications for all of the equipment.

### 2. Testing

Provide test equipment and system set-up and diagnostic software required for the testing, operation, maintenance and troubleshooting of the equipment, along with Operations, Installation and Maintenance manuals for these software packages.

Submit a start-up testing procedure for Department approval prior to commencing any testing.

## **B. Equipment Cabinet Assembly**

Submit materials submittal data for the equipment cabinet and all individual component and hardware items that make up the complete assembly. These items shall include, but are not limited to, cabinet shell specifications, electrical component description and performance specifications, wiring and cabling equipment and materials, electrical/power specifications, and all documentary items.

Submit materials submittal data for all materials and hardware necessary for the patch and electrical cabling, conduit and power service. These items include but are not limited to cabling, wire and conduit materials, service disconnect breaker/surge suppression/termination/housing description and performance specifications, ground rod and conductor, proposed conduit route from service point to equipment cabinet, and all miscellaneous hardware and accessories.

## **939.2 Materials**

### **A. Equipment**

#### **1. Power Strips**

Use commercial heavy-duty, metal, 15 amp power outlet strips as recommended by the equipment rack or equipment frame manufacturer. When installing new power outlet strips in existing equipment racks or equipment frames, use the same type and rating as those power outlet strips originally installed with the equipment rack or equipment frame. Do not install outlet adapters/expanders or non-commercial power outlet strips.

#### **2. Terminal Server**

For Hubs, furnish multiport Terminal Servers, Type A that are compatible with the existing NaviGator serial port control system. The existing serial port control system consists of terminal servers (Digiboard PortServer II) and as required, host-based serial port concentrators (Digiboard EPC/X and EPC/CON system), addressed with the Digiboard RealPort system interface.

Configure the Terminal Servers, Type A with 8Mb RAM, RISC processor and forty-eight (48) RJ45 serial device ports, unless otherwise noted in the Contract Documents. Configure the Terminal Servers, Type A as a single terminal server assembly consisting of individual EIA 19 inch rack-mounted units with a minimum of 16 serial device ports per unit and a maximum vertical height of 1.75 inch (44.4 mm) per unit, and one internal 120VAC power supply for a complete terminal server assembly. Do not use external 120VAC power supplies.

As required to provide a network interface for legacy equipment, furnish Terminal Servers, Type B that meet the following minimum requirements:

- Compatible with existing Navigator serial port control system
- Compatible with the Field (Ethernet) Switches furnished and installed.
- IP addressable, TCP/UDP socket support, support Ethernet 10/100Base-T/TX (10/100Mbps)
- Minimum of two (2)-port conversion capability.
- Operational temperature range from -20 to 70° C; up to 90% humidity, non-condensing
- Fully compliant with RS-232 (RS-422/485 support as needed) ports
- Support SNMP management capabilities, web interface, telnet
- Support full and half-duplex operation.
- Interface connectors to Field Switch shall be RJ-45
- Power: nominal input voltage of 120 VAC 60 Hz. The unit shall be provided with all power conversion which is temperature hardened from -20 to +70 degrees C and all regulation necessary to support electronics operation. The power input circuitry shall be designed to protect the electronics from damage by a power surge or under voltage

condition. All power transformers provided shall be “fastening mechanism” type. No plug-in types will be provided. All corded transformers shall be mountable with the ability to neatly secure power cords.

- Include UL approval
- Capable of being rack mounted in Equipment Cabinets

### 3. Patch Cords

- a. General Requirements: Verify that patch cords consist of a length of cable that is connectorized on both ends, primarily used for interconnecting termination or patching facilities and/or equipment.

All patch cords shall be factory assembled and connectorized and be certified by the patch cord manufacturer to meet the relevant performance standards required below. All connectors shall incorporate mechanical cable strain relief and protective boots.

- b. Coaxial Video Patch Cords: Ensure that coaxial video patch cords are 75-ohm precision double-shielded cables with stranded center conductor. Use BNC connectors with gold-plated center pins at both ends. Connectorized coaxial video patch cords shall be 100% sweep tested.

Provide only adapters with gold-plated pins.

- c. Network/Field Switch/Data Patch Cords: Verify that network//field/data patch cords meet all ANSI/EIA/TIA requirements for Category-5 4-pair unshielded twisted pair cabling with stranded conductors and RJ45 connectors.

- d. Voice/Telephone Patch Cords: Provide voice/telephone patch cords that meet all ANSI/EIA/TIA requirements for Category 3 unshielded twisted pair cabling with stranded conductors, unless otherwise required by the voice/telephone equipment manufacturer.

### 4. Video Monitor

Provide monitors that meet the following minimum specifications:

- Size: 20" (500 mm) [19" (480 mm) viewable]
- Resolution: 500 TV lines at center
- AG pitch: 0.4 mm
- Frequency response: 6 MHz +/- 3dB
- Color temperature: 6500K
- Comb filter
- Beam current feedback
- Dimensions: 17.7" (450 mm) (W) x 17.36" (440.9 mm) (H) x 19.8" (503 mm) (D)
- Color standards: NTSC, PAL, SECAM
- Connectors: Video in/out (BNC), Audio in/out (RCA)
- Rack mountable metal cabinet

### 5. Hub Uninterruptible Power Supply

Ensure the hub UPS provides AC back-up power for network electronics and other equipment as shown in the contract documents. Provide a hub UPS meeting the following requirements:

- 19" rack mounted, maximum height of 6 rack units
- 120 VAC single phase 60 HZ output

- Input line cord plug type NEMA L5-30P
  - 8 output receptacles type NEMA5-15R
  - Pure sine wave output at 115 VAC +/- 5%
  - Transfer time of 4 ms or less
  - Capacity of 2200 VA/1600 W
  - Load factor range of 0.5 to 1.0
  - Peak current capability of 6.5 KVA
  - Software adjustable high and low voltage buck/boost function
  - SNMP manageable hardware and software with 10Base-T connection (RJ-45)
  - SNMP addressable with physical IP address configuration (e.g., dip switch, thumb wheel)
  - Addressable SNMP command set shall minimally include: UPS state, battery condition (capacity, age, internal temperature); current AC input conditions (voltage, phase, frequency, failure condition); current AC output conditions (voltage, frequency, load); and diagnostic/self-test control and status.
  - Remote environmental sensing hardware and software integrated with SNMP minimally capable of temperature and humidity monitoring and 4 dry contact closures
  - Network connection to Ethernet port on Hub Network Switch, Layer 3 GigE
  - SNMP management user interface and MIB software package for HP OpenView UX10.2 operating system, fully licensed to the Department
  - Sealed maintenance-free lead-acid batteries
  - Maximum audible noise of <53 dBA at 3 ft (0.9 m).
  - Upgradeable for increased runtime capacity (minimum 2.5X) with additional battery packs
  - Expansion battery pack that is 19" rack mounted, with maximum height of 5 rack units
6. Network Switch, Layer 3 Gig-E

For Hubs, furnish a Gigabit Ethernet Layer 3 network routing switch that is compatible with the existing GDOT Ethernet switching network. The existing network consists of Nortel Networks 8600 Layer 3 routing switches. The network switches shall be manageable using the Department's existing Device Manager network management software. Configure the network switch(es) at the locations shown in the Plans, as applicable, to the following minimum requirements:

- Minimum 6 slot chassis with hot-swappable card capability
- Two (2) Enterprise Routing Switch Module CPU/Switch Fabric modules with PCMCIA flash memory card
- One (1) 8-port 1000 Base Gigabit interface converter (GBIC) Enterprise Routing Switch module.
- One (1) 48-port auto-sensing 10Base-T/100Base-TX Ethernet Layer 3 switching interface module.
- Three (3) 100-240VAC power supplies including North American power cables, configured for 120VAC service
- Passport 8600 routing switch software license V3.x or newer, including license, agent software, management software, and all software documentation
- EIA 19" rack mounted

Additionally configure each Network Switch, Layer 3 GigE, Type A, with four (4) 1000Base-XD fiber-optic single-mode GBICs with a minimum 17dB optical power budget. Include four (4) duplex fiber optic single-mode patch cords, 30 ft. (9 m) in length, in accordance with Section 935 and with ST-connectors on one end (at the FDC) and an SC-connector on the other end (at the network switch.)

Additionally configure each Network Switch, Layer 3 GigE, Type B, with four (4) 1000Base-ZX fiber-optic single-mode GBICs with a minimum 22dB optical power budget. Include four (4) duplex fiber optic single-mode patch cords, 30 ft. (9 m) in length, in accordance with Section 935 and with ST-connectors on one end (at the FDC) and an SC-connector on the other end (at the network switch.)

Additionally configure each Network Switch, Layer 3 GigE, Type C, with six (6) 1000Base-SX fiber-optic multi-mode GBICs with a minimum 7dB optical power budget. Include six (6) duplex fiber optic multi-mode patch cords, 30 ft. (9 m) in length, in accordance with Section 935 and with ST-connectors on one end (at the FDC) and an SC-connector on the other end (at the network switch.)

Additionally configure each Network Switch, Layer 3 GigE, Type D, with two (2) 1000Base-ZX fiber-optic single-mode GBICs with a minimum 22dB optical power budget and four (4) 1000Base-SX fiber-optic multi-mode GBICs with a minimum 7dB optical power budget. Include two (2) duplex fiber optic single-mode patch cords, 30 ft. (9 m) in length, in accordance with Section 935 and with ST-connectors on one end (at the FDC) and an SC-connector on the other end (at the network switch.) Include four (4) duplex fiber optic multi-mode patch cords, 30 ft. (9 m) in length, in accordance with Section 935 and with ST-connectors on one end (at the FDC) and an SC-connector on the other end (at the network switch.)

#### 7. Gigabit interface converter (GBIC) Enterprise Routing Switch Module

As required, provide a Gigabit interface converter (GBIC) Enterprise Routing Switch Module which consists of eight (8) 1000Base ports populated with GBICs as called-out on the Plans and as specified herein. All Modules and GBICs provided shall be compatible with the Network Switch, Layer 3 GigE.

#### 8. Gigabit interface converter (GBIC)

The GBICs shall meet the following minimum requirements:

1. Support single-mode operation
2. Fully compliant with IEEE 802.3z standards
3. Operate at 1000Mbps and full-duplex operation supporting the following types:
  - o GBIC, Type A (LX): (SMFO at 1310nm); Link budget: 10.5dB, typical
  - o GBIC, Type B (XD): (SMFO at 1550nm); Link budget: 17.0dB, typical
  - o GBIC, Type C (ZX): (SMFO at 1550nm) Link budget: 22.0dB, typical
4. Allow for hot swapping failed components
5. Operate as it's own switched port
6. Support detecting and shutting down one-way link failures, using auto-negotiation

#### 9. Field Switch

All Field Switches shall meet the following requirements:

##### General Characteristics and Capabilities:

1. Meet the IEEE 802.3 (10Mbps Ethernet) standard.
2. Meet the IEEE 802.3u (Fast Ethernet 100 Mbps) standard
3. Provide a minimum of three (3), Gigabit-Ethernet GBIC sockets
4. Provide a minimum of six (6) 10/100 Base TX ports. Each 10/100BaseTX port shall connect via RJ45 connector. The ports shall operate as half-duplex or full-duplex (IEEE 802.3x) over 100m segment lengths and provide auto-negotiation.

5. The optical receiver saturation level shall be greater or equal to the maximum optical output of the transmitter minus 1db.
6. Bit Error Rate shall not decrease over the optical channel when two units are connected with a fiber optic jumper having total optical losses of 1dB, including connector losses.
7. Operate non-blocking, at full wire speed
8. Support remote reset and remote management
9. Minimum MTBF of 100,000 hrs using Bellcore TS-332 standard.

#### Network Capabilities and Features:

The Field Switch shall support/comply with the following minimum requirements:

1. Provide full implementation of IGMPv2 and IGMP snooping
2. Meet the IEEE 802.3x (Full Duplex with Flow Control) standard.
3. Meet the IEEE 802.1p (Priority Queuing) standard.
4. Meet the IEEE 802.1Q (VLAN) standard per port for up to four VLAN's.
5. The switch shall meet the IEEE 802.1D (Spanning Tree Protocol) and IEEE 802.1w (Rapid Spanning Tree) standards.
6. Meet the IEEE 802.3ad (Port Trunking) standard for a minimum of two groups of four ports.
7. Full implementation of GMRP (Generic Multicast Registration Protocol).
8. Full implementation of GVRP (Generic VLAN Registration Protocol).

#### Port Security:

The Field Switch shall support/comply with the following (remotely) minimum requirements:

1. Ability to configure static MAC addresses access
2. Ability to disable automatic address learning per ports; know hereafter as Secure port. Secure Ports only forward statically configured Mac addresses.
3. Trap and alarm upon any unauthorized MAC address and shutdown for programmable duration. Port shutdown requires administrator to manually reset the port before communications are allowed.

#### Network Management Functions:

The Field Switch shall support/comply with the following minimum requirements:

1. Password manageable
2. Full implementation of SNMPv1 and SNMPv2c.
3. Full implementation of RMON I and RMON II.
4. Capable of mirroring any port to any other port within the switch.

#### Remote Management and Configuration:

The Field Switch shall support/comply with the following minimum requirements:

1. SNMP
2. Telnet/CLI
3. HTTP (Embedded Web Server) with Secure Sockets Layer (SSL).
4. Full implementation of RFC 783 (TFTP) to allow remote firmware upgrades.

#### Mounting:

The Field Switch shall be rack mountable as shown on the Detail Drawings in this section. All necessary hardware and adaptors for mounting shall be included.

#### Environmental:

The Field Switch shall support/comply with the following minimum requirements:

1. Operate between -34 to +70 degree Celsius. (-29°F to +158°F)

2. Operate from 10% to 90% humidity

#### Electrical/Safety:

The Field Switch shall support/comply with the following:

1. Operate from 100 VAC to 200 VAC (120VAC nominal, 60Hz) as shown on the Detail Drawings in this section.
2. The Field Switch shall be provided with all power conversion which is temperature hardened from -34 to +70 degrees C and all regulation necessary to support electronics operation. The power input circuitry shall be designed to protect the electronics from damage by a power surge or under voltage condition.
3. All power transformers provided shall be “fastening mechanism” type. No plug-in types will be provided. All corded transformers shall be mountable with the ability to neatly secure power cords.
4. Include UL approval

#### Status Indicators:

The Field Switch shall support/comply with the following minimum requirements:

1. Power: On, Off
2. Network Status per port: Transmit, Receive, Link, Speed
3. Status indicators shall be LED.

#### Field Switch Types:

In addition to meeting all the requirements specified herein, the Field Switch GBIC sockets shall be populated as indicated on the Plans. The Field Switch types are defined as follows:

1. Field Switch, Type A – three (3) GBIC, Type A (LX)
2. Field Switch, Type B – one (1) GBIC, Type A (LX) and two (2) GBIC, Type B (XD)

## 10. Video Encoders and Decoders

All Video Encoder/Decoder equipment and software shall comply with the following minimum specifications:

#### Video and Data Requirements

- The Video Encoder/Decoder, Type A, configuration shall support the following video features:
  1. Simultaneous transmission of both MPEG-2 and MPEG-4 video streams. Each stream shall be independently IP addressable and independently enabled or disabled. The encoder and decoder unit itself shall be addressed using only one IP address for configuration and management.
  2. Signal Format: Up to 30 fps, NTSC color
  3. Support the following resolutions (minimum):
    - 720 x 480 (Full D1 resolution)
    - 352 x 240 SIF/CIF
    - 176 x 120 (QSIF)
- The Video Encoder/Decoder, Type A, configuration shall support bi-directional serial communications over Ethernet via the following methods:
  1. Encoder serial port to Decoder serial port data stream
  2. IP socket to Encoder/Decoder serial port
  3. Above methods shall implement user selectable protocol stack as either UDP/IP or the TCP/IP protocols
- The communications method shall be user selectable.
  1. The Video Encoder/Decoder, Type A, configuration shall support full-duplexed serial interface and data rates up to 112kbps (minimum). The baud rate, stop bits, data bits, and flow control shall be user configurable. The serial interface shall be transparent to the device (i.e. no additional or special protocols shall be used to communicate between the CCTV control interface.

### Encoder Video/Encoding

- The Video Encoder, Type A, configuration shall comply/support the following:
  1. Encoding formats: MPEG-2 ISO/13818-2 and MPEG-4 ISO/IEC 14496-2 encapsulated in a User Datagram Protocol (UDP) packet. Real Time Protocol (RTP) shall also be supported.
  2. For network transport comply with ISO/13818-1, Systems for MPEG-2 video streams and Internet Streaming Media Alliance (ISMA) for MPEG-4 video streams.
  3. Each stream shall be capable of being configured and addressed independently.
  4. Dynamic bandwidth control: Up to 6Mbps (MPEG-2 encoder appliance) and 2Mbps (MPEG-4 encoder appliance) or greater, auto-detecting (The data rate shall be defined as the maximum committed bandwidth to be utilized, which includes data bursting.) The default bandwidth for the MPEG-2 shall be set to 5Mbps and 384Kbps for MPEG-4. Bandwidth increments shall be user configurable via the network.
  5. At a 5Mbps video stream rate provide a latency/delay of less than 300mSec (defined from video appliance to video appliance) with no video artifacts and disruptions.

### Physical and Environmental Specifications

- The Video Encoder/Decoder, Type A, configuration shall have the following ports:
  1. Network: Minimum of one (1) 10/100 Mbps RJ-45
  2. Video: One (1) composite binary network connector (BNC). Two-way video splitters shall not be used to generate MPEG-2 and MPEG-4 streams from a single CCTV NTSC video signal.
  3. Data: Minimum of two (2) ports, configurable to EIA-232 (RS-422 and/or 485 shall be supported as needed) mode of operation. No adaptors shall be permitted.
- The video input performance at the Encoder input shall comply with NTSC and EIA requirements, including the EIA-170 standard, with a composite video of 1 volt peak-to-peak (Vp-p). The equipment shall have an electrical resistance of 75 ohms per 60 hertz (Hz).
- The Video Encoders, Type A, used at field locations shall operate between -20°C to +70°C (-4°F to +158°F), with the relative humidity between 10% and 90%, non-condensing.
- The Video Decoders, Type A, shall operate in the following environment: Temperature ranging from 0°C to +50°C (+32°F to +122°F), and a relative humidity between 10% to 90% non-condensing.
- The Encoders/Decoders, Type A, shall provide a minimum local status display capability for activity, link, network, video loss, transmit and receive (each serial port), and power. Status indicators shall be LED.
- Cable connections (signal / power) shall require no tools for installation or removal and be designed with positive locking devices such that they will not vibrate loose.
- Provide external markings -- all connectors, indicators, and replaceable components shall be permanently marked and traceable to the supplied documentation, including schematics and parts list. The external markings shall include the product function name, model number, serial number, and manufacturer's name.

### Serial Data Interface

- Each Video Encoder/Decoder, Type A, shall have a minimum of two (2) EIA-232 serial interface port (RS-422 and/or 485 shall be supported as needed). External RS-232/422/485 interface converters are not acceptable. This port shall be configurable, directly or over the network, to EIA-232 mode of operation as defined by the Electronic Industries Alliance (EIA) for data format, data rate, and data structure (e.g., the number of bits, parity, stop bits, etc.) via the management software provided.
- Each Video Encoder, Type A, shall use the serial interface port to support PTZ camera control functions. Serial port(s) shall support up to 112 Kbps (minimum).
- Serial port(s) shall support IP addressing and socket number selection in both UDP/IP and TCP/IP protocols. These protocols shall be user selectable on a per port basis.

- The equipment shall provide the capability to establish an IP connection directly from a workstation to any encoder IP address and socket number transport serial data.

#### Network / Video Transmission Method

The Video Encoder/Decoder, Type A, shall comply/support the following:

- Ethernet Interface (10/100Base-T protocol, Full/Half-Duplex, Auto Sense (802.3), RJ-45).
- User selectable on a per stream basis; Elementary Stream (ES) and Transport Stream (TS). TS to be transmitted over Ethernet as follows: TS/RTP/UDP/IP/Ethernet as per RFC 2250 and ISMA compliance.
- Allow for transmissions over Category-5/5e unshielded twisted pair (UTP)/shielded twisted pair (STP) network cables compliant with the EIA and Technology Industries Association's (TIA) requirements as detailed in the EIA/TIA standard; an attached fiber optic media converter (i.e., an Ethernet switch); or an IP wireless device.
- Static IP Addressing (class A, B, and C) or via Dynamic Host Configuration Protocol (DHCP).
- UDP Unicast and IP Multicast (Internet Group Multicast Protocol / IGMPv2) features for digital video transmission
- Support Session Announcement Protocol (SAP).

#### Closed Captioning

- Provide the capability for closed captioning (dynamic messaging with ability for the viewer to be able to turn on or off the message on screen).

#### Text Insertion and Display

- Provide the capability to insert text into the encoded stream with user configurable text messages with a minimum of five (5) lines of 24 characters. Each of the inserted field's position in the view shall be configurable, using X-Y coordinates.
- Dynamic messaging shall be provided through a published API provided to the Department.
- Encoders shall be able to generate a date and time stamp in the video stream.

#### Video Capture

- Provide the capability for video capture at the Encoder. The encoder shall capture a video frame and transfer ("push") it out periodically in JPEG format every "N" seconds to a server using the FTP protocol. "N" shall be user-defined and shall have a lower limit of 5 seconds.
- Video capture shall be provided without the need for an internal hard drive or any other hardware with movable components.

#### Encoder/Decoder Management System

The Video Encoder/Decoder, Type A, shall have the minimum capability to be managed through SNMP (v2), HTTP (embedded web server), and Telnet/CLI. The management system shall be provided to remotely configure and diagnose the Encoders/Decoders.

The Video Encoder/Decoder, Type A shall be provided with the capability to reset/reboot and firmware upload via the methods listed above.

The Video Encoder/Decoder, Type A shall be firmware upgradeable to future algorithm (i.e., H.264 video compression standard).

#### Physical and Electrical

- The Video Encoder/Decoder, Type A, shall support the following:

1. Rack mountable as shown on the Detail Drawings in this section. The encoder configuration shall be able to fit, including all mounting hardware, into one (1) rack space (1.75”) within a standard EIA 19 inch rack. The video encoder configuration shall also not exceed 13 inches in depth to accommodate the cabinet space configuration.
  2. All video encoders shall be provided with the necessary rack mounting hardware/adaptors.
  3. Power: nominal input voltage of 120 VAC 60 Hz as shown on the Detail Drawings in this section.
  4. The unit shall be provided with all power conversion, temperature hardened as specified herein and all regulation necessary to support electronics operation. The power input circuitry shall be designed to protect the electronics from damage by a power surge or under voltage condition.
  5. All power transformers provided shall be “fastening mechanism” type. No plug-in types will be provided. All corded transformers shall be mountable with the ability to neatly secure power cords. Dual power supplies are not acceptable unless provided in a redundant configuration.
  6. Include UL approval
- The Video Encoder/Decoder, Type A, shall be provided with:
    - 1 Surge protection for a 100% over voltage condition for a 10msec duration and with a response time of 1psec or less.
    - 2 Automatic recovery from an over or under voltage condition when prime power has returned to the tolerance values specified herein. No reprogramming or manual adjustments shall be required upon power recovery.

#### 11. Ethernet Hub

Verify that the Ethernet hub is connected to the Ethernet transceiver and is compatible with the NaviGator system network management. Provide an Ethernet hub meeting the following minimum specifications:

- 12 Port RJ-45 10Base-T outputs
- Rack mounted
- IEEE 802.3 standard
- Front panel media ports

#### 12. NaviGator Workstation

As required, the NaviGator workstation shall comply with the following minimum requirements:

- Processor: Minimum Intel® Pentium® IV 3GHz (or higher) with 1MB L2 cache
- Memory: 512MB of RAM 512k cache
- Floppy Drive: 1.4MB 3.5-inch
- Hard Drive: 80GB (minimum) 12ms access EIDE or SCSI
- CD-RW: 24X CDRW DRIVE
- Graphics/Video Card and Video Streaming Software Application: 32-bit PCI video with 128Mb RAM with dual monitor driver. Support real-time MPEG-2 and MPEG-4 video streaming and capture applications.
- Integrated Gigabit Ethernet (1000Base-T/TX) capability
- Input Devices: Minimum 104-key keyboard and optical 2-button mouse
- Case: Mid-tower with power supply
- Expansion: Minimum of 1 PCI slot remaining after installation of all specified boards
- Ports (minimum):

1. Enhanced Parallel Port
  2. 2 Serial Ports on the motherboard
  3. 1 10/100-BaseT network interface port
  4. 2 USB 2.0 ports
  5. 1 IEEE 1394 firewire port
- Dual color flat-panel (digital/analog) monitors: 20-inch LCD display, capable of 1600 x 1200 resolution; 400-to-1 Contrast Ratio and 250nits Brightness.
  - Video Input Connectors, minimum:
    1. Analog RGB
    2. Digital DVI-D
  - Soundblaster compatible sound card with integrated speakers
  - Microsoft Windows XP or NT, latest version
  - Antivirus software, latest version

### 13. Video Recorder

The video recorder will be remotely controlled by the NaviGator software and shall be fully compatible with the existing NaviGator serial control protocol. Ensure that the supplied equipment meets the following minimum requirements.

- Recording and playback of NTSC/RS170 standard video and audio
- Multifunction RS-232 serial remote control
- Capable of confirming its operational status upon request
- Multi-speed operation from VHS SP and EP plus time lapse operation up to 960 hours on a standard 2 hour VHS tape
- Mountable in a standard 19" rack opening

### 14. Equipment Rack

Provide equipment racks as applicable and required within the equipment cabinets as specified herein.

### 15. Equipment Frame

Provide equipment frames meeting the following requirements:

Overall dimensions of approximately 84" (210 mm) high by 20.25" (514.4 mm) wide and meeting EIA standards for mounting 19" (480 mm) equipment.

Equipment frame upright channels fabricated from 6061-T6 aluminum extrusions with minimum depth of 5.75" (146 mm), flange thickness of 0.19" (4.8 mm) and web thickness of 0.16" (4.1 mm).

Equipment frame upright channels manufactured with threaded #12-24 mounting holes of entire channel length front and rear with standard EIA spacing. Do not use non-threaded clearance holes with separate "clip nuts".

Provide front and rear mounting base angles fabricated from 6061-T6 aluminum extrusions with minimum 6" (150 mm) footing extension. Secure base angles to floor with a minimum of four 0.625 threaded expansion anchor bolts with steel or brass expansion sleeves. Do not use any other type of anchor.

Provide front and rear top angles fabricated from 6061-T6 aluminum extrusions with minimum 1.5" (38 mm) by 2.0" (51 mm) web.

Provide a front-mounted lower guard-rail fabricated from minimum 0.25" (6.4 mm) by 2.0" (51 mm) bar stock with 6.0" (150 mm) to 7.0" (180 mm) standoff from the upright channel.

Provide vertical cable management ducts in between all equipment frames and at each end of a row of equipment frames. Provide a vertical cable management duct on each side of a single equipment frame. Use vertical cable management ducts that reach from the bottom of the equipment frame fully to the top of the frame. Use ducts that are double-sided, opening to the front and rear of the equipment frames, with each side having the minimum inside dimensions of 3.5" (89 mm) wide by 6.25" (159 mm) deep. Provide plastic or rubber grommets openings, between the two sides of the duct, with a minimum opening of 2" (50 mm) and a maximum spacing of 12" (300 mm). On the front-opening of each side of the duct, provide positive cable restraint through opening latches or removable covers.

For all assembly or fastening hardware use zinc-plated steel, nickel-plated brass, or stainless steel unless otherwise specified.

Use a black color finish on upright channels, top and base angles, and lower guard rails.

With each equipment frame provide a minimum of 50 #12-24 x 0.75" (19 mm) (minimum) cuphead phillips-slot mounting screws with pilot points and nylon washers. Use zinc-plated steel, nickel-plated brass, or stainless steel screws. Provide more screws if necessary to properly mount all equipment as shown in the Plans.

Provide a rear-mounted, 20-amp, 10-receptacle power strip secured with a minimum of four rigid standoff brackets. Do not use threaded bolts or rods as standoff brackets.

Perform all assembly and installation in accordance with the equipment frame manufacturer's recommendations.

## 16. Dial-up Modem

As required, furnish and ensure that the dial-up modems are stand-alone modems that support programmable communication rates of 0-56,000 bps and provide fully automatic communications rate selection. Provide modems meeting the following minimum specifications:

- Modulation: V.34, V.90, V.32
- Protocol: Asynchronous and synchronous supported
- Error control: V.42
- Hayes standard AT command set
- Automatic speed buffering
- Flow control
- (2) Modular RJ-11 telephone line connectors
- Modular DB-25 RS-232C serial interface connector
- LED indicators for TX, RX, RTS, DCD, PWR

## 17. Media Converter

- a. General: As required, furnish and use only media converter equipment and network management software from the same supplier, and use only media converter modules, including system management modules, that are compatible and interchangeable with any chassis installed on the project.

Install all media converter modules into the chassis with which they are specified. Provide all equipment installation, materials, incidentals and configuration to provide a complete and accepted end-to-end system providing the full communications function as defined by the media converter module type.

- b. Management Software, Type A: Provide one copy with single-user license of SNMP-based network management software and documentation with each media converter management module, or as otherwise shown in the Plans. Provide network management software that operates as an HP Open View plug-in on the Sun Solaris platform. Network management software shall provide remote monitoring and management of any media converter module, chassis and all power supplies installed in a managed chassis. Monitoring and management includes status monitoring, measured network traffic parameters, environmental monitoring, and module configuration management. Provide full programming and user documentation for the network management software as well as complete documentation of all

SNMP MIBs implemented in the media converter modules, chassis and power supplies. Provide software on a Solaris-compatible standard compact disc.

- c. Chassis: Provide media converter chassis as shown in the Plans and specified here. The chassis shall minimally have the number of ports specified available for media converter modules exclusive of the management module, which may fit in a separate, additional port.

Use standalone chassis designed for desktop or shelf-top installation, with full enclosures and skid-resistant rubber or neoprene feet. For standalone chassis specified with one power supply, use internal 120VAC power supplies. Where dual power supplies are required, use internal modular, removable 120VAC power supplies with plug-and-socket connections only. One- and two-port standalone chassis with one power supply shall have maximum dimensions of 9 in. (230 mm) (W) x 9 in. (230 mm) (D) x 3 in. (76 mm) (H). Four-port and larger standalone chassis shall have maximum dimensions of 19 in. (49 mm) (W) x 16 in. (410 mm) (D) x 8 in. (200 mm) (H).

Use rack-mount chassis designed for 19-inch EIA rack or frame mounting with front-mount rails only and no separate shelf or support brackets needed. Use rack-mount chassis mounting brackets that are interchangeable with the front and rear of the chassis such that the media converter modules can face either the front or the rear of the equipment rack or equipment frame. Install the chassis with the modules facing the front of the equipment rack or equipment frame unless otherwise shown in the Plans. Use internal modular, removable 120VAC power supplies with plug-and-socket connections only. Rack-mount chassis shall have a maximum height of 7.25 in. (184 mm) and depth of 18 in. (460 mm). Provide a separate rack-mount wire management panel located directly below the chassis. Use a wire management panel with at least four plastic or plastic-coated cable rings and no more than 1.75 in. (44.4 mm) in height.

For all chassis, provide sufficient blank panels, from the chassis manufacturer, to close all chassis ports after the specified media converter modules have been installed.

Provide one or more 120VAC power supplies internal to the chassis as specified in the Plans. Do not use external power transformers or converters. Where dual power supplies are specified, each power supply shall be a separate independent unit compatible with either power supply slot and shall be hot-swappable. Power supplies in managed chassis shall be monitored by the management module and software.

Managed chassis shall include a removable system management module addressable by the network management software through a dedicated IEEE 802.3 compliant 10/100BaseT auto-sensing Ethernet interface with RJ45 UTP connector. Provide a network/data patch cord, in accordance with 939.2.A, to connect the management module as shown in the Plans. The system management module shall include front-panel LEDs for module power status, Ethernet link status, and Ethernet link activity. Unmanaged chassis do not include a system management module nor a specific port for same.

Provide media converter chassis with the following configurations:

- Media converter, chassis, type A, shall be an unmanaged, standalone, one-port chassis with single power supply.
- Media converter, chassis, type B, shall be a managed, standalone, one-port chassis with single power supply.
- Media converter, chassis, type C shall be an unmanaged, standalone, four-port chassis with single power supply.
- Media converter, chassis, type D shall be a managed, standalone, three-port chassis with single power supply.
- Media converter, chassis, type E shall be a managed, rack-mount, 10-port chassis with dual power supplies.

- d. Modules: Provide media converter modules as shown in the Plans and specified here. Install modules in chassis ports as specified for the chassis.

Provide modules that are compatible and interchangeable with any port in any chassis provided on this project. Provide modules that are hot-swappable without affecting the operation of any other module in that chassis.

Provide sufficient patch cords, in accordance with 939.2.A, to fully connect the module as shown in the Plans. Media converter modules shall have two sets of ports for the two different media being converted unless otherwise specified. Fiber optic ports shall be ST unless otherwise specified. Ethernet and serial data ports shall be female RJ45 unless otherwise specified.

Provide media converter modules with the following configurations:

- Media converter, module, type A, shall be an Ethernet-to-fiber optic converter used for extended LAN connections. The Ethernet port shall be a dedicated IEEE 802.3 compliant 10/100BaseT auto-sensing Ethernet interface. The fiber optic port shall be a two-fiber 1310nm or 1550nm single-mode connection with a minimum 15dB optical power budget and a minimum transmission distance of 12 mi. (19 km). The module shall include front-face LED indicators for module power, RJ45 connector link status, RJ45 connector link speed, RJ45 link activity, TX optical link status, RX optical link status, optical link activity, and link collisions.

## **B. Equipment Cabinet Assembly**

### 1. General

Ensure that all cabinets exhibit a smooth, uniform natural aluminum finish.

All bolts, nuts, washers, screws, hinges and hinge pins shall be stainless steel.

Manufacture the exterior mounting bracket and fixtures of aluminum or galvanized steel, and manufacture all fastening and mounting hardware of stainless steel. Verify that the bottom of the pole-mounted cabinet is fully enclosed. Where base-mounting of equipment cabinets is specified, the cabinet bottom shall be open.

Verify that all electrical cables between the cabinet and the device are UL-listed tray cable with #18 AWG 16-strand copper conductors with PVC/nylon insulation and a UV-resistant PVC outer jacket rated for 600V, 190 °F (90 °C) dry, 170 °F (75 °C) wet and wet/dry direct burial use. Conductor color-coding shall be in accordance with ICEA Table K.2/Method 1.

### 2. Standard Cabinet Housing

- a. General Requirements: Unless otherwise specified, furnish cabinet housings that conform to the Cabinet Housing Details as defined in Chapter 6, Section 2 (Housing Number 2) and the Cabinet Housing Details of the Caltrans specification. The police panel and associated wiring circuits are not required as part of this cabinet assembly. All cabinets shall have hooks, welded to the inside of the front cabinet door, for hanging the plastic documentation pouch.

Unless otherwise specified in the Plans, configure all equipment cabinet assemblies for pole mounting. The holes for pole mounting shall be properly reinforced with metal plates of adequate size and strength welded longitudinally across the inside depth of the cabinet. Where base-mounting of equipment cabinets is specified, make the cabinet bottom open and provide an approved base mounting adapter, in accordance with the Department's Standard Specification for Traffic Signal Equipment.

- b. Type A Standard Cabinet Housing - Not Applicable
- c. Type B Standard Cabinet Housing – Not Applicable

- d. Type C Standard Cabinet Housing: The Type C cabinet housing (see Detail Drawings) is a standard Model 332 housing with approximate exterior dimensions of 64 in. (1.6 m) (H) x 24 in. (0.61 m) (W) x 30 in. (0.76 m) (D).

Equip all Type C cabinet housings with the standard EIA 19-inch rack cabinet cage as described in Section 3 of the Caltrans specification. Install side panels within the two sides of the cabinet cage as shown on the Detail Drawings in this section. Each side panel shall be fabricated from 5052 sheet aluminum alloy with a minimum thickness of 0.125 in (3.175 mm).

Equip Type C cabinet housings with a cabinet sliding drawer. Follow the drawer specifications given in Subsection 939.2.B.5.

Provide a ground fault interrupt 15A duplex receptacle (NEMA 5-15R) in the cabinet as an accessory outlet. Install two (2) non-ground fault protected 15A equipment outlet strips, each with 10 receptacles. Mount the strip outlets vertically near the top of the cabinet as shown in the Detail Drawings in this section.

- e. Type D Standard Cabinet Housing: The Type D cabinet housing shall be a standard Model 336 stretch (336S) housing with approximate exterior dimensions of 46 in. (1.2 m) (H) x 24 in. (0.61 m) (W) x 23 in. (0.58 m) (D). The minimum door opening dimensions shall be 40.5 in. (1.03 m) (H) x 22 in. (0.56 m) (W).

Equip all Type D cabinet housings with the standard EIA 19-inch rack cabinet cage as described in Section 3 of the Caltrans specifications and mounting panels as shown on the Detail Drawings in this section. The minimum clear vertical

inside dimension of the rack for equipment mounting shall be 39.5 in. (1.00 m). Install side panels within the two sides of the cabinet cage. Use side panels fabricated from 5052 sheet aluminum alloy with a minimum thickness of 0.125 in (3.175 mm).

Equip the Type D cabinet housing with a cabinet-sliding drawer. Follow the drawer specifications given in Subsection 939.2.B.5.

Provide a ground fault interrupt 15A duplex receptacle (NEMA 5-15R) in the cabinet as an accessory outlet. Provide rack mounted power strip outlets near the top of the cabinet as shown in the Detail Drawings in this section. The power strip shall incorporate 8 NEMA 5-15R receptacles. The power strip receptacle shall face the back of the cabinet and shall be recessed within the cabinet rack to provide a minimum spacing of three (3)-inches between the outlet's face and the cabinet door when the door is closed.

### 3. Internal Cabinet Assembly Components

Unless otherwise specified in the Plans or approved by the Engineer, construct all cabinet assemblies in conformance with this Subsection 939.2.B including all Detail Drawings, all applicable provisions of the Georgia DOT Standard Specifications for Traffic Signal Equipment, and applicable provisions of the Caltrans Specifications including Chapter 6, Section 5. Do not include with the cabinet assembly the power supply assembly, power distribution assembly, input file, output file, monitor unit assembly, field terminal hookup blocks, and related wiring assemblies as described in Chapter 6, Sections 4, 5 and 6 of the Caltrans specifications.

Provide a plastic documentation pouch to store the cabinet and equipment documentation. Use a pouch that is side-opening, resealable, opaque, and of a heavy-duty plastic material. Use a pouch that has metal or hard-plastic reinforced holes for hanging from hooks included on the cabinet door. The pouch shall be of the size and strength to easily hold all wiring diagrams, equipment documentation and the maintenance logbook.

### 4. Wiring, Conductors and Terminal Blocks

Provide circuit breakers as shown in the Detail Drawings in this section. Use only circuit breakers that are UL approved and plainly marked with trip and frame sizes and ampere rating. All circuit breakers shall be quick-make, quick-break on either automatic or manual operation. Ensure that contacts are silver alloy and enclosed in an arc-quenching chamber. Overload tripping shall not be influenced by an ambient air temperature range from -18 degrees C to 50 degrees C. Minimum interrupting capacity shall be 5,000 amperes RMS. Use only circuit breakers that are standard panel-mount or channel-mount devices.

Use busbars fabricated from a copper alloy material compatible with copper wire. Only use busbars for termination of ground or neutral conductors. The earth ground bussbar shall have at least two positions capable of terminating a #6 AWG conductor. If using more than one ground bussbar in the cabinet, interconnect them with a minimum of #10 AWG conductor.

Use terminal blocks and strips with voltage and current ratings greater than the voltage and current ratings of the wires that are terminated on the blocks or strips (see Detail Drawings in this section). Make the terminal block for the 120VAC cabinet service entrance (SE) a tubular clamp compression device that is fully insulated (Marathon 1103P or approved equivalent) (see Detail Drawings in this section). Terminal blocks for 120VAC power wiring (TB1, TB2) shall be on dual-screen barrier type terminal blocks with 9/16 in. (14.29 mm) spacing using nickel-plated brass 8-32 phillips slot screw and fork terminal lugs (Cinch 142 or approved equivalent). TB1 shall have at least 8 terminal positions. TB2 shall have a minimum of 8 terminal positions in a Type C and D cabinet. Do not use compression-type or tubular clamp terminal blocks except for service entrance block SE. Do not use spade lug terminals for any terminal block.

### 5. Sliding Drawer

Install drawer that is an aluminum storage compartment mounted in the rack assembly with the approximate following dimensions: 1.75 in (44.4 mm) (H) x 16 in (410 mm) (W) x 14 in (360 mm) (D). Ensure the compartment has telescoping drawer guides to allow full extension from the rack assembly. When extended, the storage compartment shall open to provide storage space for cabinet documentation and other miscellaneous items. Install a storage compartment that is of adequate construction to support a weight of 25 lb (11 kg) when extended. The top of the storage compartment shall have a non-slip plastic laminate attached which covers a minimum of 90% of the surface area of the top.

## **939.2.02 Delivery, Storage and Handling**

Not applicable

## **939.3 Construction Requirements**

### **939.3.01 Personnel**

Have trained personnel available for troubleshooting and problem solving until all equipment is fully functional and ready to start the acceptance phase.

### **939.3.02 Equipment**

Not applicable

### **939.3.03 Preparation**

Not applicable

### **939.3.04 Fabrication**

#### **A. Cabinet Equipment and Components**

Install in the cabinet assembly one (1) fluorescent lighting fixture mounted inside the top front portion of the cabinet. Include with the fixture a cool white lamp, covered and operated by a normal power factor UL listed ballast. Install an RC network noise suppression filter in the light circuit. Install door actuated switches installed to turn on the cabinet light when either door is opened.

Include with the cabinet assembly a thermostatically actuated contact-closure sensor functioning as an “over temperature” alarm. The sensor unit shall be identical to the thermostat required above and set to close at 120°F (49°C).

#### **B. Cabinet Wiring, Conductors, and Terminal Blocks**

Use a maximum of two conductors on quick-clamp type terminals (terminals are described in Subsection 939.2.B.4). When using fork terminals insulate them and crimp them with a calibrated ratchet tool; install a maximum of two fork terminals at a given screw terminal position. Protect all conductors and terminals that could be hazardous to maintenance personnel with suitable insulating material. The insulating material shall be easily removed by hand for access to the conductors and terminals.

Number all terminal blocks, terminal strips, circuit breakers and bussbar breakers and have each item and each terminal position numbered and named according to function as shown in the “quoted labels” in the Detail Drawings. Label terminal blocks, terminal strips, circuit breakers and bussbars with silk-screened lettering on the mounting panel.

### **939.3.05 Construction**

#### **A. Equipment**

##### **1. Installation**

Install all equipment in new and/or existing equipment racks and equipment frames in accordance with the equipment manufacturer’s recommendations, including mounting, interconnection wiring, and electrical service. Furnish and install all mounting hardware and incidental materials, including fasteners and auxiliary supporting frames/brackets, as recommended by the manufacturer. Furnish and install all miscellaneous hardware, materials, wiring/cabling, configuration, and any other incidental items necessary for fully operational components and subsystems shown in the Contract Documents and Section 940 of the Special Provisions, except when specifically identified as existing or as work to be performed by the Department.

Work in this project may require access to various Department buildings and hubs requiring coordination of all work activities in these locations with the Engineer before access is needed. Work in this project requires system configuration tasks to be performed by the Department before some Contractor-installed items can be brought online and completely

system tested. Coordinate all work activities needing system configuration with the Engineer a minimum of 14 days prior to any testing.

Install all hub and control center equipment in the presence of the Engineer. Locate new equipment in new or existing equipment racks or equipment frames as shown in the Plans.

Provide proper electrical service, including grounding and current rating, in the equipment racks and equipment frames for all hardware installed under this project. This requirement includes existing and new equipment racks and equipment frames. Obtain Engineer approval prior to installation of all electrical service for hardware in control centers. Furnish and install additional power outlet strips in new and existing equipment racks and equipment frames if needed for the new equipment.

For any equipment that is not rack-mountable with “rack ears”, provide perforated shelves and secure all shelf-mounted equipment with rack mounting hardware.

Label all wiring and cabling, including building entrance cables, jumper and patch cords, and power supply cables, using cable identification numbers as shown in the Plans or provided by the Engineer. Apply cable labels at each end and in the center of the cable. Cable labels shall consist of permanent ink printed or legibly written on self-laminating and over-wrapping label material.

Protect cable ends at all times with acceptable end caps. Never subject any coaxial cable to a bend radius of less than six inches. Provide grommets, guides and/or strain relief material where necessary to avoid abrasion of or excess tension on wire and cable.

## 2. Terminal Server

For Hubs, install the terminal servers, Type A, in equipment frames as shown in the Plans and in accordance with the Manufacturer’s recommendations. For equipment cabinets and as required, install the terminal servers, Type B, as shown in the Plans and in accordance with the Manufacturer’s recommendations. Furnish and install all interconnection wiring and power service connections.

## 3. Patch Cords

- a. General Requirements: Use patch cords only within control center buildings, communication hubs, and equipment cabinets.

Label all patch cords using cable identification numbers as shown in the Plans or provided by the Engineer. Apply cable labels at each end and in the center of the cable. Use printer-generated adhesive overlapping cable labels.

Neatly route, dress and secure patch cords in the equipment racks or frames and at both ends. Use all available cable management devices and/or trays. Route patch cords only vertically on the sides of the equipment racks and frames or horizontally across the bottom or top of the racks and frames; no diagonal routing is permitted. Follow all manufacturer’s recommendations including bend radius requirements during all patch cord installation.

- b. Fiber Optic Patch Cords: Furnish and install fiber optic patch cords in accordance with Section 935 and this section.
- c. Coaxial Video Patch Cords: Where an equipment or termination facility has a connector other than BNC (such as an RCA), furnish and install a BNC adapter to connect the patch cord to the equipment or termination facility.
- d. Data Patch Cords: Use data patch cords to connect all local area network and RS-standard (e.g., RS-232, RS-422/485) serial data termination facilities and equipment.  

Where an equipment or termination facility has a connector other than an RJ45 outlet (such as a “D-shell” connector), furnish and install RJ45 adapters between the connectors and the network/data patch cords as approved by the Department. For any type of RJ45 adapter, provide the proper pin-out of the adapter.
- e. Network Switch/Field Switch Patch Cables: Furnish and install Category-5/5e unshielded twisted pair (UTP)/shielded twisted pair (STP) patch cables that comply with EIA/TIA-568-A standards for all network to device interconnects (device to switch).

f. Voice/Telephone Patch Cords: Use voice/telephone patch cords to connect all voice or telephone communications facilities and equipment. Furnish and install the voice/telephone patch cords with the necessary pair sizing and connector for the equipment being connected.

4. Network Switch, Layer 3 Gig-E

For Hubs, furnish and install Network Switches, Layer 3 GigE that are compatible with the existing NaviGator Ethernet network as shown in the Plans, as applicable. The existing network consists of Nortel Networks 8600 Layer 3 GigE switches.

Furnish and install the network switch and all fiber optic jumper cabling necessary to connect to the fiber optic cable FDC as shown in the Plans.

5. Hub Uninterruptible Power Supply

Furnish and install a dedicated electrical service branch circuit from the hub main service panel for the UPS system. Ensure that the UPS system branch circuit is in accordance with all recommendation of the UPS manufacturer, including the provision of a locking plug/receptacle connection. Make all electrical conduit and fittings rigid EMT or approved equivalent. Locate the branch circuit receptacle as close as possible to the UPS mounting position to minimize the UPS input line cord and to minimize tripping hazards.

6. Video Recorder

The video recorder control communications with NaviGator shall be by serial data interface through the terminal servers. The existing Department standard video recorder control protocol and software interface is JVC BR-S925U. A different communications protocol may be provided. However, if the equipment selected requires software device drivers / communications protocols not currently incorporated into the NaviGator software, produce and provide the necessary NaviGator software driver modules to the Department. Provide the software as part of the overall bid and follow complete NaviGator software conventions, language, methodology, etc. (Case Tools, C++, Object-oriented, UNIX). Integrate the software modules into NaviGator under the supervision of the Department's NaviGator Information Systems Manager or the Department's designated representative. Prior to the Department's acceptance of any individual video recorder from the Contractor, demonstrate to the satisfaction of the Engineer that the equipment is fully operational and controllable from the TMC through the NaviGator software.

**B. Communications Subsystem**

1. General

Use Network Switches, Layer 3 Gig-E, field switches, terminal servers, video encoders/decoders, and/or media converters and modems as necessary or required to establish

- Digital data communications between local controllers and system masters
- Digital camera video and control data communications to and from equipment cabinets/hubs/control centers
- Digital sign control data communications to and from equipment cabinets/hubs/control centers
- Digital detector data communications to and from equipment cabinets/hubs/control centers

Furnish and install Network Switches, Layer 3 Gig-E, field switches, terminal servers, video encoders/decoders, and/or media converters and modems as necessary or required as specified in the Plans to ensure proper communications.

2. Installation Requirements

Install all communications equipment and materials necessary for a complete communications path from the field site to the control center or communications hub as shown in the Plans. Furnish and install all mounting and interconnection materials, including but not limited to card cages, mounting panels and rack hardware, fiber, patch/jumper cables, and power supply cables. Mount card cages and mounting panels as shown in the Plans and Detail Drawings in this section. Furnish and install the type and quantity of equipment shown in the Plans. Where the Plans show that new field switches, video encoders, video processors, and other devices are to be placed in existing cabinet space, furnish and install compatible mounting hardware, as required.

Label all wiring and cabling, including entrance cables, jumper and patch cords, and power supply cables. Cable labels shall consist of permanent ink printed or legibly written on self-laminating and over-wrapping label material.

- a. Equipment Cabinet Mounting: All field equipment shall be mounted in a manner as to not restrict the replacement of other components in the cabinet housing.
- b. Hub/Control Center Mounting: Where data is transmitted to a receiving end such as a hub, TCC or TMC, permanently mount the equipment as required within an equipment rack, frame.

### 3. Radar Dial-up Modem

Furnish and install all cabling required to connect the radar dial-up modems to the telephone lines and the radar workstation.

### 4. CMS Dial-up Modem

Furnish and install all cabling required to connect the CMS dial-up modems to the telephone lines and the CMS workstation.

### 5. Media Converter

Furnish and install all patch cords as shown in the Plans and power service connections. Provide all equipment installation, materials, incidentals and configuration to provide a complete and accepted end-to-end system providing the full communications function as defined by the media converter module type.

## **C. Equipment Cabinet Assembly**

### 1. General Requirements

Furnish and install the equipment cabinet assembly to include all devices/components, assembly, wiring and materials required in this Subsection 939.3.05.C and in Subsection 939.2.B.

The equipment cabinet assembly, as described below, shall conform to all applicable sections of the Caltrans specifications and Georgia DOT Standard Specifications.

### 2. Classification of Types

Furnish and install equipment cabinet assemblies as called for in the Plans in accordance with the following requirements for each type.

- a. Type A Cabinet – Not Applicable.
- b. Type B Cabinet – Not Applicable.
- c. Type C Cabinet: Furnish and install a Type C Cabinet that conforms with all materials and installation requirements of this Subsection 939.3.05.C and Subsection 939.2.B using a Type C Standard Cabinet Housing (see Detail Drawing in this section).
- d. Type D Cabinet: Furnish and install a Type D cabinet assembly that conforms with all materials and installation requirements of this Subsection 939.3.05.C and Subsection 939.2.B using a Type D Standard Cabinet Housing (see Detail Drawing in this section).

### 3. Identification and Documentation

Include the manufacturer's name only on the inside of the front cabinet door along with the cabinet model number, serial number, schematic wiring diagram number, and month/year of manufacture. Provide this information on a waterproof, permanently affixed label.

Identify all components of the cabinet assembly, which are mounted on panels. Make identification on the panels with permanent silk-screen or other printed labels. These components include but are not limited to terminal blocks (with all positions numbered and labeled), panel and socket mounted surge suppressors, circuit breakers, accessory and equipment outlets, and communications transmitters/transceivers.

Provide complete documentation with each cabinet. Identify all cabinet documentation, including the maintenance logbook, by field site name and system ID. Make all cabinet documentation (except that documentation contained in the maintenance logbook below) on ledger size non-fading xerographic black-on-white 20# or greater bond paper. Supply four sets of schematic wiring diagrams with complete parts lists with each cabinet. Draft the diagrams in neat, workmanlike manner. The diagrams shall be completely legible at the specified paper sizes and be non-proprietary. Identify in the diagrams all circuits in a manner as to be readily interpreted. Include in the diagrams a cabinet drawing showing the equipment layout in a front and rear elevation view and front views of each of the side panels. Label all equipment on the drawings with the same identifiers as labeled on the panels themselves. Identify all cabinet electrical components and equipment and the ventilation filter on parts lists on the wiring diagrams or in the maintenance logbook. The parts lists shall include manufacturer and complete model number. Store the diagrams in the documentation pouch on the door.

Include in the cabinet documentation an equipment list and maintenance logbook. This maintenance logbook shall contain a list of all major removable equipment items in the cabinet and all major items installed outside of the cabinet including but not limited to field switch, video encoders, video processors, CCR, camera, lens, housing, and pan/tilt unit, along with manufacturer name, model, and serial numbers. Include in the equipment list in the logbook spaces to enter the communications address, system identifier, and other site-specific configuration information. The maintenance logbook shall include a minimum of five blank forms for documenting site visits, including the date, time, technician name, and work performed. The maintenance logbook pages shall be standard letter size 3-hole 20# or greater white paper bound in a plastic report cover.

#### 4. Internal Cabinet Assembly Components and Wiring

- a. Cabinet Assembly Installation: Install the cabinet assembly as shown in the Plans. Provide the cabinet assembly with a grounding system in accordance with the Department's Standard Specification for Traffic Signal Equipment grounding. Measure the resistance to ground in the presence of the Engineer. Resistance to the ground cannot exceed 10 ohms. Do not splice the ground conductor between the cabinet grounding terminal and the ground rod. Isolate and insulate the ground conductor from any utility grounding equipment. Completely isolate the cabinet assembly grounding system from any other grounding system, including the support pole grounding system, such that there is no electrical bond between any equipment (cabinet, conduit, camera support bracket, etc.) and any other grounding system. In the case of steel support poles, it is not necessary to insulate equipment strapped to the pole.

Mount all pole mounted cabinet assemblies to the support pole at a height of 4 ft +/- 3 in (1.2 m +/- 76 mm) from ground level to the centerline of the cabinet housing. Where the Plans show base-mounted cabinets, install the cabinets in accordance with the Department's Standard Specification for Traffic Signal Equipment installations.

Enclose all cabling and wiring entering the cabinet housing in conduit. Securely and neatly dress all cabling and wiring inside the cabinet, including field wiring. Provide sufficient slack (minimum 2 ft. (600 mm)) for cabinet equipment maintenance and re-termination of the field wiring. Route fiber drop cables into the cabinet to provide as much physical protection as possible. Secure the drop cables through the cabinet, and strain-relieve them within the fiber termination unit.

- b. Wiring, Conductors and Terminal Blocks: Use stranded copper for all conductors, including those in jacketed cables, except for earth ground conductors, which may be solid copper. Neatly arrange all wiring, firmly lace or bundle it, and mechanically secure the wiring without the use of adhesive fasteners. Route and secure all wiring and cabling to avoid sharp edges and to avoid conflicts with other equipment or cabling. Route camera control wiring, and 120VAC power wiring separately. Terminate all wiring on a terminal block, strip, bussbar, or device clamp or lug; do not splice any wiring. Use a minimum #12 AWG for all conductors of 120VAC circuits. Install all wiring as shown in the Detail Drawings.
- c. Surge Suppression: Make filtering surge suppression for AC power service to the cabinet housing (SS1) in accordance with the Department Standard Specification for Traffic Signal Equipment for Surge Protection, AC Service Input (EDCO SHA 1210 or approved equivalent). Cover all non-grounded line terminals on the suppressor with suitable rubber caps to prevent accidental contact with hazardous voltages; silicone caulking material is not permitted.

Protect all copper wiring and cabling entering the cabinet housing, except for the earth ground conductor, by surge suppression devices as specified. Terminate all wiring between cabinet devices and the transient surge suppressors, except for the video signal coaxial feed, on terminal strips. Use a minimum #16 AWG grounding of each surge suppression device, or larger if recommended by the surge suppression device manufacturer. Use insulated green wire and connect the ground wire directly to the ground bussbar. Do not "daisy chain" with the grounding wires of other devices including other surge suppressors. Dress and route grounding wires separately from all other cabinet wiring.

Install grounding wires with the absolute minimum length possible between the suppressor and the ground bussbar. Label all surge suppressors with silk-screened lettering on the mounting panel.

Use minimum #18 AWG insulated black wiring between the surge suppression device sockets and the terminal blocks for the protected circuits.

- d. Component Installation: All components/devices of the cabinet assembly are to be rack mounted with phillips-head machine screws. Install screws into tapped and threaded holes in the panels. These components/devices include but are not limited to terminal blocks, bussbars, panel and socket mounted surge suppressors, circuit breakers, accessory and equipment outlets, DC power supply chassis, video encoders, video processors, and field switches. Fasten all other cabinet components with hex-head or phillips-head machine screws installed with nuts (with locking washer or insert) or into tapped and threaded holes. These other components include but are not limited to door switches, fans, lights, thermostats, thermal blocks, and door lock mechanisms. Fasten stud-mounted components to a mounting bracket providing complete access to the studs and mounting nuts. All fastener heads and nuts (when used) shall be fully accessible with a complete cabinet assembly, and any component/device shall be removable without requiring removal of other components, panels, or mounting rails. Do not use self-tapping or self-threading fasteners.

## 5. Cables, Conduit and Power Service

Furnish and install electrical cables, conduit and power service necessary to make the system fully operational.

- a. Electrical Cables: Furnish and install electrical cables for providing electrical power service to the site and for providing telephone service from the telephone company demarcation point to the equipment cabinet.

Furnish and install electrical cables used for power service, including grounding, in accordance with the Standard Specifications for electrical, lighting and traffic signal equipment.

Furnish and install electrical cables used for power supply as shown in the Detail Drawings. Do not splice any cable, shield or conductor used for power supply. Identify all conductors of all cables by color and number. Identify the conductor function in as-built documentation included in the cabinet documentation.

Electrical cables installed for telephone service from the telephone company demarcation point to the equipment cabinet shall be minimum #22 AWG twisted pair, UV-resistant shielded cable rated for wet/dry direct burial use. Install telephone service cable directly to or into the equipment cabinet in accordance with telephone company procedures. Install telephone service cable from the telephone company demarcation point to the equipment cabinet. Unless otherwise shown in the Plans or directed by the Engineer, install the telephone cable underground in conduit of minimum 1 in. (25 mm) diameter. Make all necessary connections at the telephone interface box and inside the equipment cabinet for proper operation of the video, control signaling and communications signaling. Neatly coil a minimum of 2 ft. (0.6 m) of telephone service cable in the bottom of the cabinet.

- b. Electrical Conduit: Install electrical conduit to provide enclosures for electrical cables at or terminating at the site. Furnish and install electrical conduit in accordance with the Standard Specifications for electrical, lighting and traffic signal equipment, and as required below.

Make all aboveground electrical conduit and conduit bodies rigid metal except as noted below. Terminate all aboveground conduit in either a weather head or in a cabinet. All conduits entering a pole-mounted equipment cabinet shall enter through the bottom with at least one conduit body with a sealable, removable cover for pulling access. All conduits entering in a base-mounted cabinet shall enter through the foundation and the base-mount adapter.

Install minimum 1 in. (25 mm) diameter electrical conduits for electrical power service drops to the cabinet. Conduits used as risers from a cabinet shall be minimum 2 in. (50 mm) diameter. Make nipples, welded collars, conduit bodies (e.g., LB condulets) and weather heads in hollow metal or concrete poles at the device mounting locations and at the cabinet mounting locations a minimum 2.5 in. (63 mm) diameter.

- c. Electrical Power Service: Furnish and install materials and equipment to bring electrical power service to the cabinet from the source shown in the Plans. Furnish and install electrical power service in accordance with the Standard Specifications for electrical, lighting and traffic signal equipment, and as required below.

Provide and terminate electrical power service equipment at the power service source as shown in the Plans. If the power service source is shown as a new power service drop, then furnish and install an electrical power service assembly at the new service drop location in accordance with the Standard Specifications. Include, as a minimum, with the electrical

power service equipment at a new drop a service disconnect, surge arrestor, grounding electrode and conductor, and all necessary conduit, wiring and hardware. Provide a ground conductor, other than the electrical service conduit, between the electrical service disconnect ground buss and the equipment cabinet service entrance terminal block SE. Furnish and install a service metering base where required by the local utility or electrical codes or where shown in the Plans. Include a minimum 30 ampere circuit breaker with electrical service disconnects. Mount the electrical surge arrestor on the disconnect housing. The arrestor shall be rated for a maximum permissible line to ground voltage of 175RMS, and shall be in conformance with NEMA standards for surge arrestors. Electrical service conduit shall be minimum 1 in. (25 mm) diameter. Separate electrical service conduit from all other conduit. This conduit cannot contain any other wiring. Dedicate electrical service conduit from the electric utility drop point through the meter base and disconnect and to the cabinet, where the electrical service conduit shall enter the cabinet through the cabinet bottom.

If the power service source is an existing service drop, then furnish and install the necessary materials and equipment to supply service to the cabinet from the existing service drop. Unless otherwise shown in the Plans, service the cabinet from a dedicated branch circuit with circuit breaker. Make all electrical service installation from the existing drop point as specified for new power service drops above.

Furnish and install surge suppression at all electrical power service sources. Ground all electrical power service sources and bond the AC neutral and ground at the power service source only.

### **939.3.06 Quality Acceptance**

The Engineer, based on justification of public interest, may order any completed or partially completed portions of the project placed in service. Such action is not an acceptance of the project in whole or in part, nor is it a waiver by the Engineer of any provision of the specifications. Assume no right to additional compensation or extension of time for completion of the work or any other concession because of the use of the project or any part thereof prior to final acceptance of the completed project. Fully maintain all equipment prior to final acceptance, which includes but is not limited to equipment configuration and communication systems.

Perform all acceptance testing in the presence of the Engineer. Notify the Engineer of a desired acceptance test schedule no less than fourteen calendar days prior to beginning the testing except for testing using the NaviGator software and existing NaviGator control center and communications equipment. For acceptance testing using the NaviGator software and existing NaviGator control center and communications equipment, coordinate the testing schedule with the Engineer no less than 30 days prior to the start of this testing. Do not conduct any testing during any State or Federal holiday.

#### **A. Equipment**

##### **1. General**

Coordinate all work activities needing system configuration with the Engineer a minimum of 14 days prior to any testing.

Work in this project includes furnishing specific equipment to the Department for configuration and use by the Department during the course of the project. Operate this equipment and maintain the proper configuration until final acceptance of the project, including throughout the project duration after the Department has started using the equipment.

##### **2. Start-up Testing**

Provide start-up testing for the various devices supplied as described herein and as further detailed in the respective equipment specification section.

The Contractor shall provide a test plan and procedures for review and approval by the Engineer prior to any testing. The Contractor shall provide all test equipment and software necessary to perform the tests. Perform all tests in the presence of the Engineer unless otherwise specified.

Include in the test plan and procedures, as a minimum, the following tests:

- Device or system power-on self test
- Conduct visual inspection of device or system to confirm presence of all components and features specified by the Contract specifications and otherwise customarily provided by the manufacturer
- Test using the built-in manufacturer's product or system diagnostics to confirm proper performance

- Test all input and output ports
- Demonstrate that all functional features of the device or system are operational
- An operational test demonstrating equipment performs as intended and as prescribed by the manufacturer and meets the requirements of the Contract specifications.

Configure the components of the device, make necessary settings or adjustments, and power-on according to the manufacturer's instructions.

### 3. Terminal Server

As required, perform the following test procedures on each Type A and/or B terminal server:

- Connect with serial cable to terminal server with PC or laptop using HyperTerminal.
- Ensure that the terminal server recognizes all ports and attached expansion modules.
- Input addressing for terminal server and reset.
- Determine successful Ethernet connectivity (link light at hub/switch).
- Successfully telnet from PC or laptop to terminal server through hub/switch.
- Print to screen configuration information that is consistent with addressing data previously entered into terminal server.

### 4. Field Switches

Prior to acceptance of any Field Switch (Types A and B), the following shall be performed:

- Stand-alone Acceptance Test (SAT)
  1. The Contractor shall provide the test plan and procedures for review and approval by the Department prior to any SAT activities. The test procedures shall provide comprehensive tests to verify and demonstrate full compliance with these specifications and device functionality. Pass and fail criteria shall be identified for each tests for review and approval by the Department.
  2. The Contractor shall provide all test equipment and software necessary to perform the tests.
  3. The Department will perform the SAT in a test area provided by the Department. A Contractor representative shall be present during the SAT.
  4. The Type A Field Switch will be assembled and connected to power in a stand-alone configuration.
  5. The Type A Field Switch will be powered up and allowed to initialize, boot and run self-diagnostic tests as defined in the Department-approved test procedures.
  6. After the Type A Field Switch has started and initialized, test procedures will be executed.
  7. After the test procedures have been executed, the Field Switch will be allowed to run, uninterrupted, for a burn-in period of seventy-two (72) hours.
  8. At the end of the burn-in period, the unit will be re-started and configuration verified.

Upon completion of all test procedures, the Contractor will be notified of SAT Field Switch acceptance or failure. If the unit fails the test, the Contractor shall replace it at no additional cost to the Department and the test procedure shall be re-started.

- Operational Test
  1. The Contractor shall provide the test plan and procedures for review and approval by the Department prior to any Operational Test activities. The test procedures shall provide comprehensive tests to verify and demonstrate full compliance with these specifications in regards to device or subsystem network performance. Pass and fail criteria shall be identified for each tests for review and approval by the Department.

2. The Contractor shall provide all test equipment and software necessary to perform the tests.
3. After successful completion of the SAT, the Department will configure and connect the Field Switch to the GDOT Network.
4. Verify communications and network control from the Field Switch to/from the Hub and TMC.
5. Verify system integrity through comprehensive diagnostics.
6. Verify 10/100Base-T interfaces and operations.
7. Verify 1000Base-X interfaces and operations.

Upon completion of all the tests, the Contractor will be notified of Operational Field Switch acceptance or failure. If the unit fails the test, the Contractor shall replace the unit at no additional cost to the Department and the test procedure shall be restarted.

#### 5. Video Encoders & Decoders (Type A)

Prior to acceptance of any Video Encoder and Decoder, Type A, the following shall be performed:

- Stand-alone Acceptance Test (SAT)
  1. The Contractor shall provide the test plan and procedures for review and approval by the Department prior to any SAT activities. The test procedures shall provide comprehensive tests to verify and demonstrate full compliance with these specifications and device functionality. Pass and fail criteria shall be identified for each tests for review and approval by the Department.
  2. The Contractor shall provide all test equipment and software necessary to perform the tests.
  3. Using the Department approved Contractor-supplied test plan and procedures, the Department will perform SAT in a test area provided by the Department. A Contractor representative shall be present during the SAT.
  4. The Video Encoder/Decoder will be assembled and connected to power in a stand-alone configuration.
  5. The Video Encoder/Decoder will be powered up and allowed to initialize, boot and run self-diagnostic tests as defined in the Department-approved test procedures.
  6. After the Video Encoder/Decoder has started and initialized, the test procedures will be executed.
  7. After the test procedures have been executed, the Video Encoder/Decoder will be allowed to run, uninterrupted, for a burn-in period of seventy-two (72) hours.
  8. At the end of the burn-in period, the unit will be restarted and configuration verified.

Upon completion of all test procedures, the Contractor will be notified of SAT acceptance or failure. If the unit fails the test, the Contractor shall replace the unit and/or update the firmware as required at no additional cost to the Department and the test procedure shall be restarted.

- Operational Test
  1. The Contractor shall provide the test plan and procedures for review and approval by the Department prior to any Operational Test activities. The test procedures shall provide comprehensive tests to verify and demonstrate full compliance with these specifications in regards to device or subsystem network performance. Pass and fail criteria shall be identified for each tests for review and approval by the Department.
  2. After successful completion of the SAT, the Contractor shall configure and connect the Video Encoder to the field switch and GDOT network.
  3. Along with the Video Encoder, the Contractor shall provide a Video Decoder unit (as specified herein), a video monitor, a laptop, and camera control application provided by the Department. The Contractor shall be responsible to provide all test equipment and software necessary to perform the tests.

4. Verify MPEG video performance over the GDOT network.
5. Verify serial data channel performance using Navigator PTZ control commands.
6. Verify and demonstrate user programmable parameters and functions.
7. Verify and demonstrate network management and remote configuration.

Upon completion of all the tests, the Contractor will be notified of Operational Test acceptance or failure. If the unit fails the test, the Contractor shall replace the unit and/or update the firmware as required at no additional cost to the Department and the test procedures shall be re-started.

### **939.3.07 Contractor Warranty and Maintenance**

Provide a Manufacturer's support (usual and customary warranties) period for all equipment and materials furnished and installed as part of the Communications and Electronic Equipment System. Include in warranty and support all Contractor or Manufacturer activities related to maintenance, removal and replacement of parts and materials during the period of support. Begin the Manufacturer warranty support period upon successful completion of equipment cabling and component testing as outlined in Subsection 939.3.06. All Manufacturer warranties shall be continuous throughout the period and state that they are subject to transfer to the Department.

### **939.3.08 Training**

Provide training as required herein. Include with training all supplies, equipment, materials, handouts, travel, and subsistence necessary to conduct the training. Furnish a training notebook in a labeled 3-ring binder to each trainee. Include in the cost of training all supplies, equipment, materials, handouts, travel, and subsistence necessary to conduct the training.

Provide installation, operations, and maintenance training on the equipment at a site near the project area. Personnel trained by the various equipment manufacturers and authorized by said manufacturers shall perform the training. Provide installation, operations and maintenance training for up to twelve (12) people. Include in this training both classroom training and hands-on training. Limit in-shop and in-field training to group sizes of four (4) people at a time. Conduct all training in half-day sessions. Two half-day sessions may be held on the same day. The total of the training shall consist of at least six (6) clock hours of training for each participant. Provide a course content of, at a minimum, the following:

#### Field Switches

- Unit set-up and configuration
- Diagnostic and maintenance
- Performance tuning
- Hands-on use of Field Switches for each trainee

#### Video Encoders and Decoders

- Installation of all digital video compression system equipment
- Explanation of MPEG-2 and MPEG-4 digitized video
- Maintenance of all digital video encoder and decoder system components including software
- Measurement of digital video signals
- Hands-on use of digital video transport system equipment for each trainee

If CCTV training is also required in the project, digital video transport system training shall be provided in conjunction with the CCTV training specified herein. If so, the total of the CCTV and digital video transport system training shall consist of at least eight (8) clock hours of training for each participant. Meet all CCTV training requirements of Subsection 936.3.08.

## 939.4 Measurement

### A. Equipment

For each equipment unit listed below, furnish and install all mounting and interconnection materials, including but not limited to card cages, mounting hardware, fiber, jumper cables/patch cords, and power strips and supply cables at no separate cost to the Department. If software device drivers/communication protocols not currently incorporated into NaviGator software are needed, provide and integrate them at no separate cost to the Department.

#### 1. Terminal Server

Terminal servers (Type A & B) are measured for payment by the number actually installed, complete, functional and accepted. For each unit provided, furnish and install any required terminal servers and serial port concentrators as specified in Subsection 939.2.A.2 and in the Plans at no separate cost to the Department.

#### 2. Video Monitor

Video monitors are measured for payment by the number actually installed, complete, functional and accepted.

#### 3. Hub Uninterruptible Power Supply

Hub uninterruptible power supplies are measured for payment by the number actually installed, complete, functional and accepted.

#### 4. Network Switch, Layer 3 Gig-E

Layer 3 GigE network switches are measured for payment by the number actually installed, complete, functional and accepted. For each unit provided, furnish and install any required switching hubs, router and switching chassis as specified in Subsection 939.2.A.6 and in the Plans at no separate cost to the Department.

#### 5. GBIC Enterprise Routing Switch Module:

GBIC Enterprise Routing Switching Modules are measured for payment by the number actually installed, complete, functional and accepted.

#### 6. GBICs

GBICs (Types A, B, C) are measured for payment by the number actually installed, complete, functional and accepted.

#### 7. Field Switches

Field Switches (Types A and B) with rack mounting hardware are measured for payment by the number actually installed, complete, functional and accepted.

#### 8. Video Encoders and Decoders

Video Encoders and Decoders (Type A) with mounting rack hardware are measured for payment by the number actually installed, complete, functional and accepted.

#### 9. Ethernet Hub

Ethernet hubs are measured for payment by the number actually installed, complete, functional and accepted.

#### 10. Navigator Workstation

Navigator Workstations are measured for payment by the number actually installed, complete, functional and accepted.

#### 11. Video Recorder

Video recorders are measured for payment by the number actually installed, complete, functional and accepted.

#### 12. Equipment Rack

Equipment racks are measured for payment by the number actually installed, complete, functional and accepted.

13. Equipment Frame

Equipment frames are measured for payment by the number actually installed, complete, functional and accepted.

14. Media Converter

Media Converters with mounting hardware are measured for payment by the number actually installed, complete, functional and accepted.

15. Modem Shelves

Modems shelves are measured for payment by the number actually installed, complete, functional and accepted.

**B. Dial-Up Modems**

As required, dial-up modems are measured for payment by the number actually installed, complete, functional and accepted. For each unit installed, furnish and install all mounting and interconnection materials, including but not limited to card cages, shelves, hardware, fiber, jumper cables, RS-232/422/485 converters and power supply cables at no separate cost to the Department.

**C. Equipment Cabinet Assembly**

Equipment cabinet assemblies are measured for payment by the number actually installed, complete, functional and accepted. For each unit installed, furnish all required items, including but not limited to identification and documentation, lighting, contact switch, fan, contact-closure sensor, patch cords, cables, conduit and power service from the power service assembly to the cabinet at no separate cost to the Department.

**D. Electrical Power Service Assembly**

Electrical power service assemblies are measured for payment by the number actually installed, complete, functional, and accepted. For each assembly installed, furnish all required items, including but not limited to conduit, riser, wiring, hardware, disconnect, meter base, and Class 3, 30 ft. (9 m) timber pole at no separate cost to the Department.

**E. Testing**

Testing is measured as a lump sum for full delivery of testing and acceptance requirements.

**F. Training**

Training is measured as a lump sum for all supplies, equipment, materials, handouts, travel, and subsistence necessary to conduct the training.

**939.4.01 Limits**

Not applicable

**939.5 Payment**

Payment is full compensation for furnishing and installing the items complete in place according to this Specification. Payment for all items is as follows:

Item No. 939	Terminal Server, Type A	Per Each
Item No. 939	Terminal Server, Type B	Per Each
Item No. 939	Type C Cabinet	Per Each
Item No. 939	Type D Cabinet	Per Each
Item No. 939	Electrical Power Service Assembly	Per Each

Item No. 939	Network Switch, Layer 3 Gig-E	Per Each
Item No. 939	GBIC Enterprise Routing Switch Module	Per Each
Item No. 939	GBIC, Type A	Per Each
Item No. 939	GBIC, Type B	Per Each
Item No. 939	GBIC, Type C	Per Each
Item No. 939	Field Switch, Type A	Per Each
Item No. 939	Field Switch, Type B	Per Each
Item No. 939	Video Encoder, Type A	Per Each
Item No. 939	Video Decoder, Type A	Per Each
Item No. 939	Hub Un-interruptible Power Supply	Per Each
Item No. 939	Ethernet Hub	Per Each
Item No. 939	Navigator Workstation	Per Each
Item No. 939	Equipment Rack	Per Each
Item No. 939	Equipment Frame	Per Each
Item No. 939	Modem Shelf	Per Each
Item No. 939	Video Recorder	Per Each
Item No. 939	Video Monitor	Per Each
Item No. 939	Testing	Lump Sum
Item No. 939	Training	Lump Sum

#### **939.5.01 Adjustments**

Not applicable

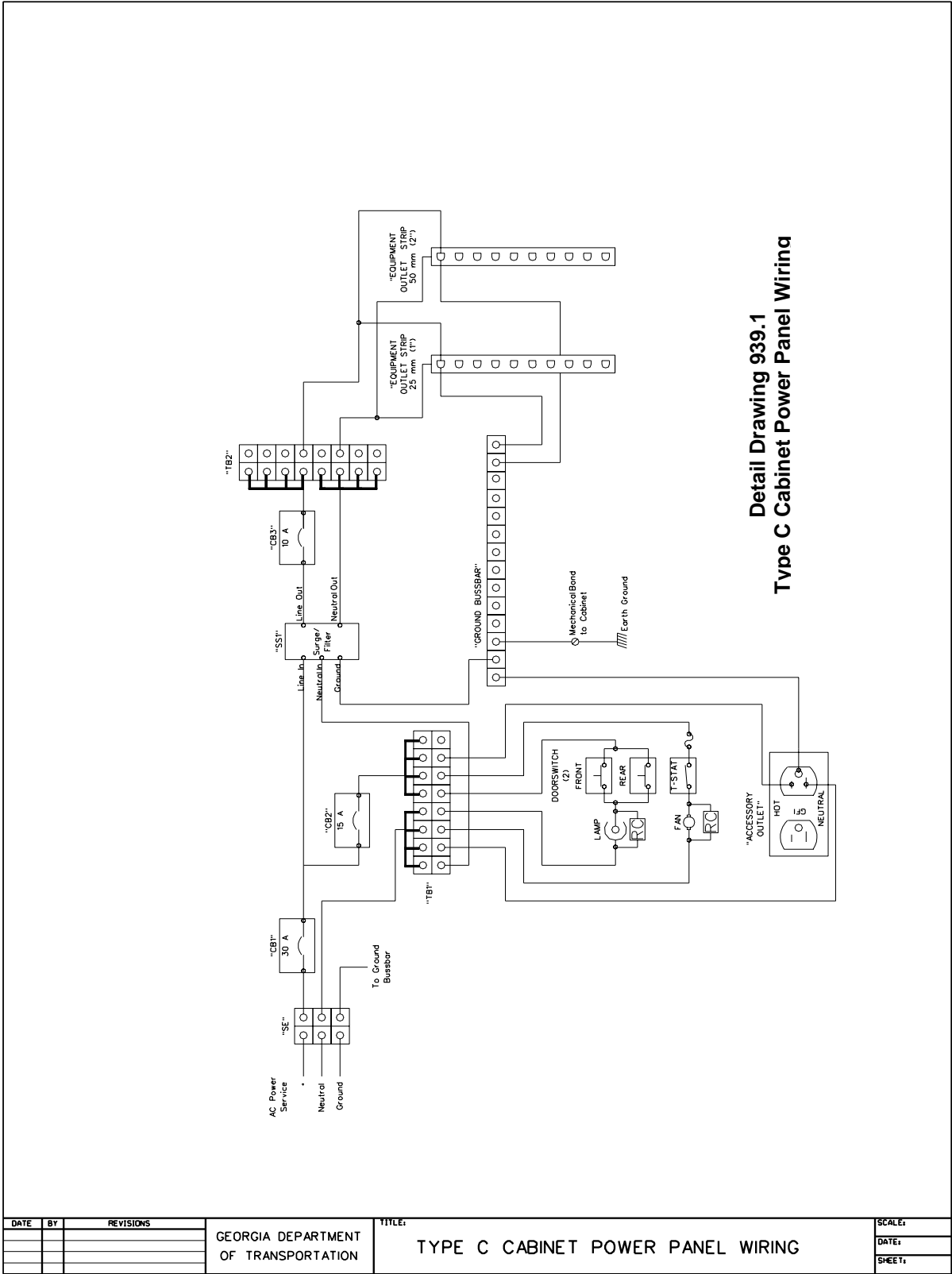

**Detail Drawing 939.1**  
**Type C Cabinet Power Panel Wiring**

DATE	BY	REVISIONS

GEORGIA DEPARTMENT  
 OF TRANSPORTATION

TITLE:  
**TYPE C CABINET POWER PANEL WIRING**

SCALE:
DATE:
SHEET:

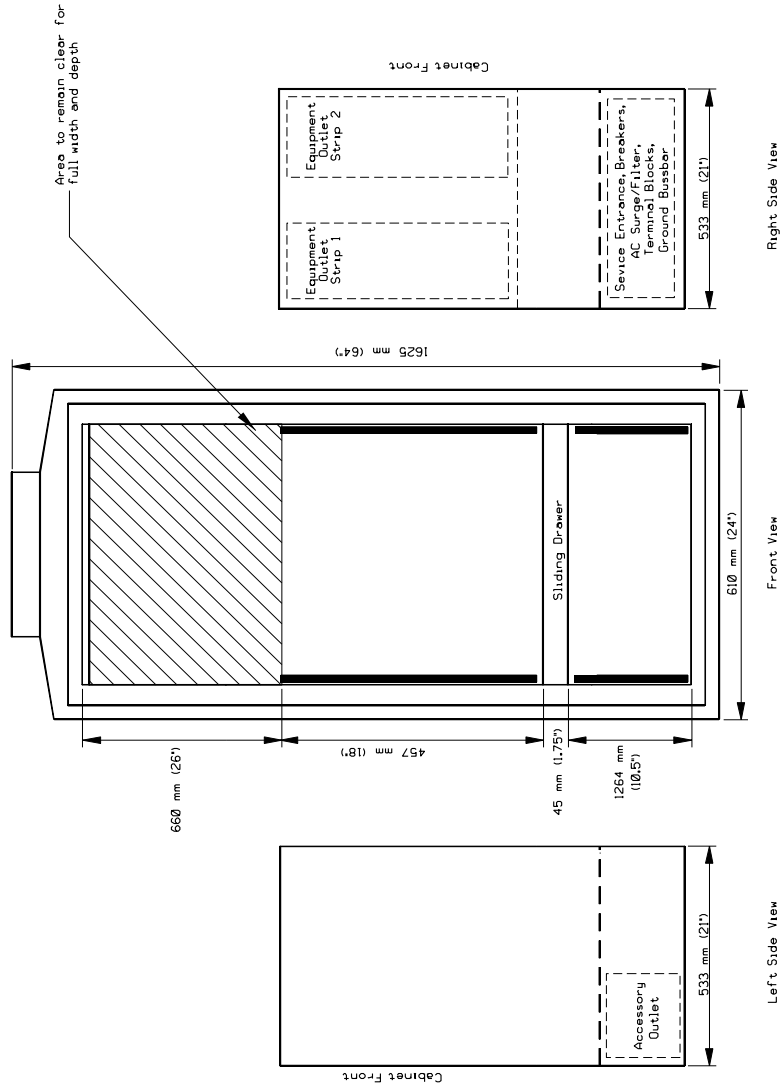

TYPE C CABINET ASSEMBLY  
NOT TO SCALE

Detail Drawing 939.7  
Type C Cabinet Assembly

Note:  
1. All dimensions and scale are approximate.

DATE	BY	REVISIONS

GEORGIA DEPARTMENT OF TRANSPORTATION

TITLE:

TYPE C CABINET ASSEMBLY DETAIL

SCALE:

DATE:

SHEET:

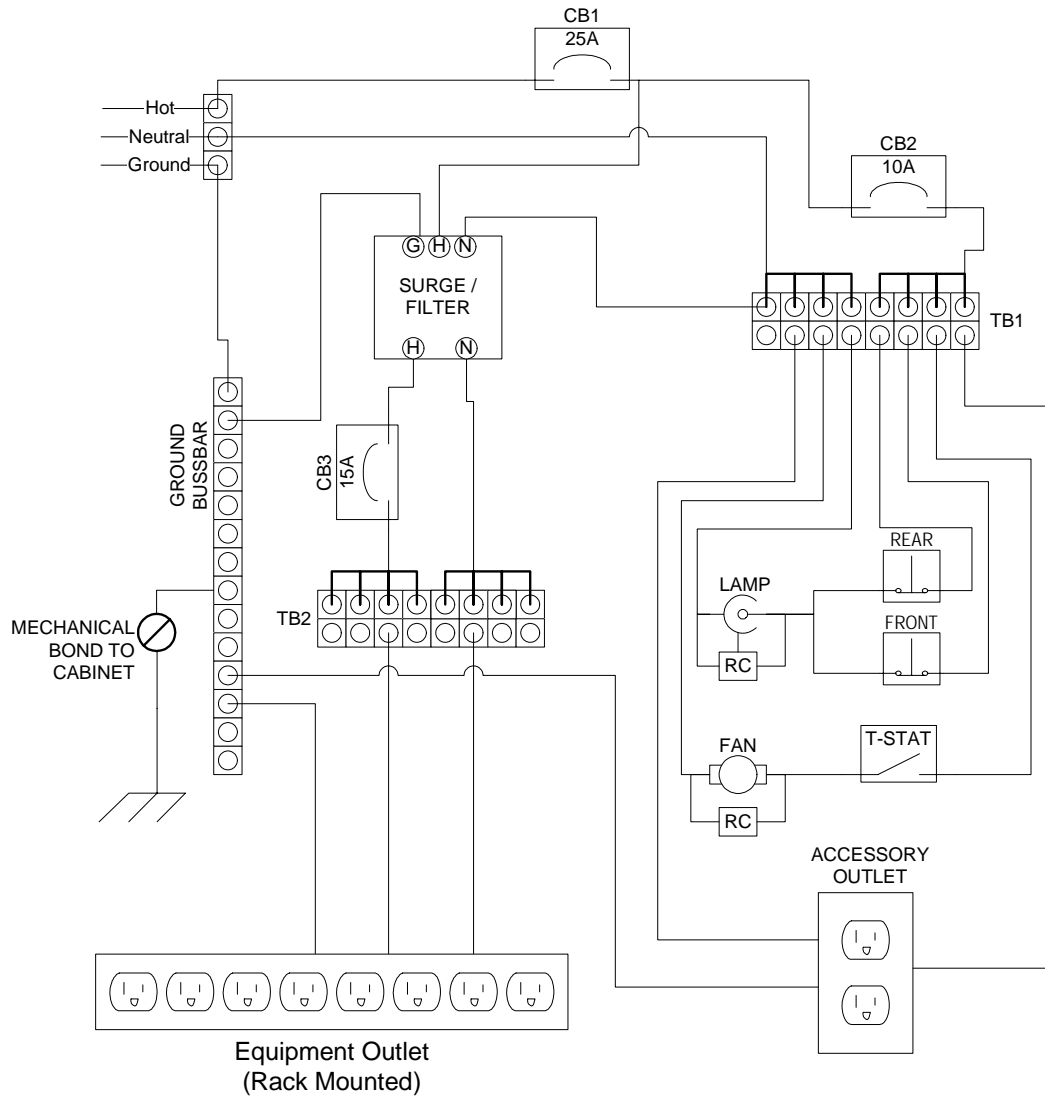

**Detail Drawing 939.3**  
**Type D Cabinet Power Panel Wiring**

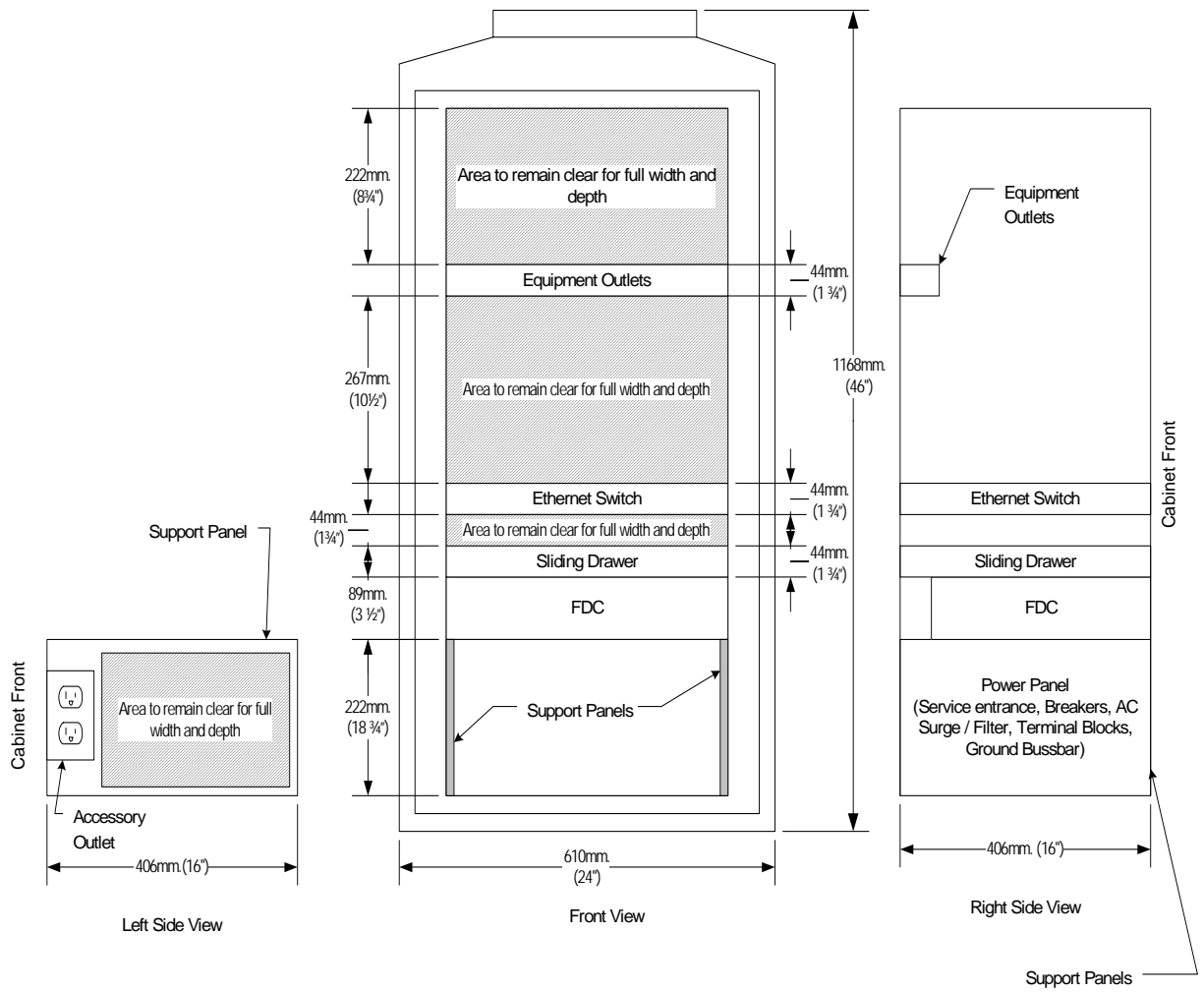

- Notes:
1. All dimension and scale are approximate.
  2. FDC (Fiber Distribution Center) required and paid for in Section 935
  3. Support Panels shall be mounted inside the cabinet rack cage.
  4. Removal of a Support Panel or Mounting Panel shall not require the removal of any other cabinet component

## Detail Drawing 939.4 Type D Equipment Cabinet Assembly

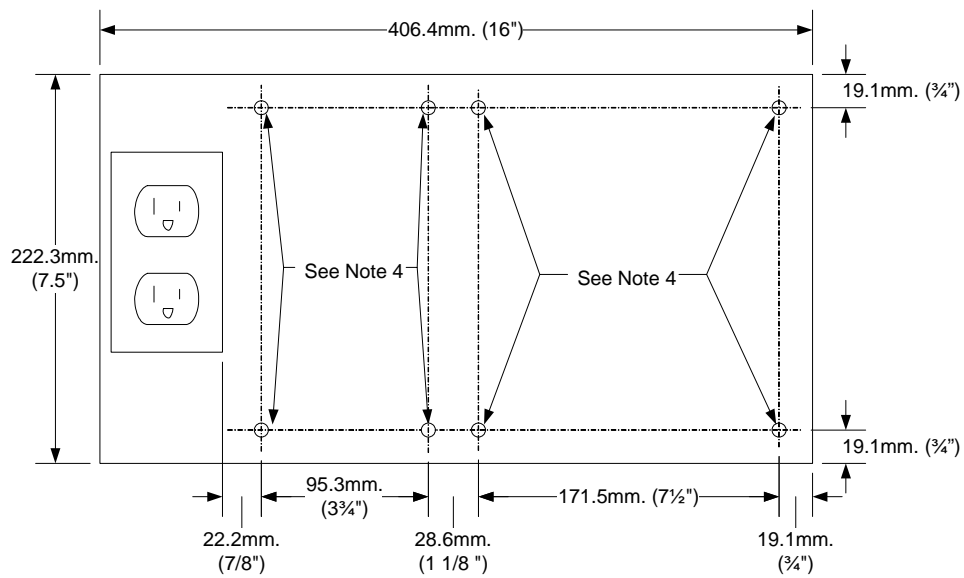

Note:

1. All linear dimensions  $\pm 0.005"$  tolerance.
2. Drawing not to scale
3. Mounting Panel shall be 0.125" 5052 Aluminum
4. Holes shall drill and tapped for 5/16-18 bolts

**Detail Drawing 939.5**  
**Support Panel, Type D Cabinet**

OFFICE OF TRAFFIC SAFETY AND DESIGN